



**CLEANDiesel<sup>®</sup>**  
Solutions for Diesel Fuel Cleanliness



ENGINEERING YOUR SUCCESS.



# PRODUCT CATALOG

## Hydraulic & Fuel Filtration Division

---

Publication Number: 2300-CD\_R-  
2300-CD Issue 1, Dated: October 1, 2016

### **SAFETY WARNING**

**FAILURE OR IMPROPER SELECTION OR IMPROPER USE OF THE PRODUCTS DESCRIBED HEREIN OR RELATED ITEMS CAN CAUSE DEATH, PERSONAL INJURY AND PROPERTY DAMAGE.**

This document and other information from Parker-Hannifin Corporation, its subsidiaries and authorized distributors provide product or system options for further investigation by users having technical expertise.

The user, through its own analysis and testing, is solely responsible for making the final selection of the system and components and assuring that all performance, endurance, maintenance, safety and warning requirements of the application are met. The user must analyze all aspects of the application, follow applicable industry standards, and follow the information concerning the product in the current product catalog and in any other materials provided from Parker or its subsidiaries or authorized distributors.

To the extent that Parker or its subsidiaries or authorized distributors provide component or system options based upon data or specifications provided by the user, the user is responsible for determining that such data and specifications are suitable and sufficient for all applications and reasonably foreseeable uses of the components or systems.

## CONTACT INFORMATION

Parker Hannifin Corporation  
Hydraulic & Fuel Filtration Division  
16810 Fulton County Road #2  
Metamora, OH 43540



[www.parker.com/hydraulicfilter](http://www.parker.com/hydraulicfilter)  
Main Phone: 419 644 4311

Technical E-mail: [HFDtechsupport@parker.com](mailto:HFDtechsupport@parker.com)  
Technical Phone: 419 644 0294

Customer Service E-mail: [HFDinsidesales@parker.com](mailto:HFDinsidesales@parker.com)  
Customer Service Phone: 419 644 0232

Service E-mail: [HFDcmcsupport@parker.com](mailto:HFDcmcsupport@parker.com)  
Service Phone: 419 644 0294

# Table of Contents

	Type	Flow	Page	
<b>Filtration for Diesel Fuel Handling</b>			5	
<b>Filtration &amp; Condition Monitoring Solutions</b>			6	
<b>Primary Markets</b>			8	
	<b>Diagnostic Products</b>		9	
	Velcon Contaminant Analyzer (VCA®)		10	
	icountACM20		12	
	icountFS		15	
	icountBSplus		18	
	Integrated Particulate Monitor (IPM™)		22	
	Flow Differential Pressure Module (FDPM™)		25	
	icountPD		27	
	Hydrokit®		35	
	Par-Test™		36	
	Low Range DIGI Water Kit		39	
	<b>Therapeutic Products</b>		41	
	Guardian®		42	
	Diesel Fuel Cart (DFC)		47	
	DFS Series		51	
	<b>Preventive Products</b>		53	
<b>Fluid Additives</b>				
	Diesel Conditioner Plus		54	
	Diesel Winter Conditioner Plus		56	
<b>Elements</b>				
	DFO	Particulate	58	
	Aquacon®	Water Absorption	60	
	DI/DO & DSO	Coalescer/Separator	62	
	Par<>Fit DFI	Particulate	64	
<b>Filter Vessels</b>				
	System Sizing		68	
	DVF 61/62	Particulate & Water Absorption	70 gpm (265 lpm)	70
	DVX	Particulate, Water Absorption & Coalescer/Separator	175 gpm (662 lpm)	73

# Table of Contents

DVF Series	Particulate & Water Absorption	80
<i>DVF8 Series</i>	176 gpm (665 lpm)	87
<i>DVF16 Series</i>	704 gpm (2665 lpm)	88
<i>DVF20/28 Series</i>	2688 gpm (10174 lpm)	89
<i>DVF36 Series</i>	4032 gpm (15261 lpm)	90
<i>DVF42/48 Series</i>	7392 gpm (27979 lpm)	91
DV Series	Coalescer/Separator	92
<i>DV22 Series</i>	330 gpm (1250 lpm)	96
<i>DV28 Series</i>	660 gpm (2498 lpm)	97
<i>DV36 Series</i>	1540 gpm (5828 lpm)	98
<i>DV42 Series</i>	2100 gpm (7949 lpm)	99
DFS Series	System	100
<b>Appendix</b>		
Laboratory		105
Interpreting Data		106
Definitions		107
Micrometer Conversions		109
Measurement Conversion Table		110
ISO4406 Codes		112
Maintenance & Safety		113
Recommended Manual Drain Hookup		114
Assembly Torque Recommendations		115
<b>Total System Health Management Overview</b>		118
<b>Non-Standard Configuration Form</b>		119
<b>Offer of Sale</b>		121

# Filtration for Diesel Fuel Handling



CLEAN Diesel®

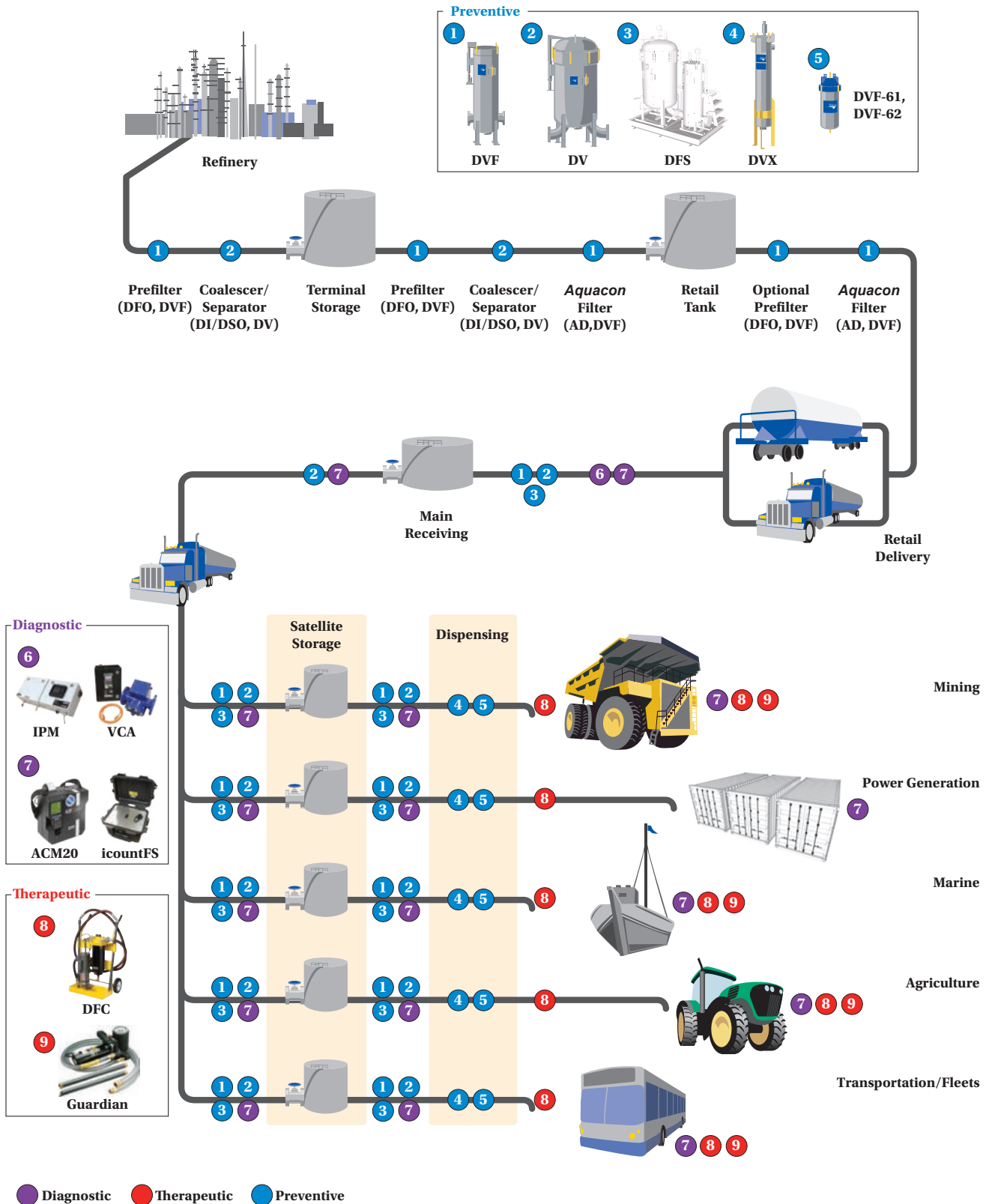

# Filtration & Fuel Condition Monitoring

## Solutions Ensuring Clean, Dry Fuel

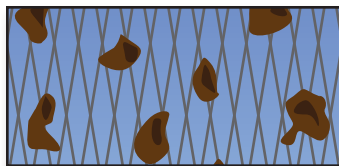

### Particulate Filtration

Removing fine and abrasive silica and pipe scale particles reduces engine wear, increases uptime and allows our customers to meet equipment warranty specifications. From 5 to 5,000 gpm (23 to 22,730 lpm), DFO Series filters can meet critical downstream ISO 4406 Cleanliness Standards in both bulk and dispensing (Point-of-Use) applications.

- Reduced operating costs due to fewer repair and replacement of equipment
- Reliable engine performance with ISO 4406 cleanliness standards compliant fuel
- Extends uptime as less maintenance is required
- More efficient fuel consumption

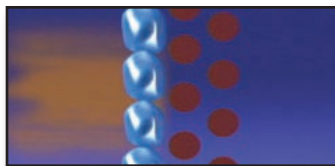

### Protection from particulate and Water (Absorption)

Parker HFF has been the leader in providing products that can absorb (chemically bind) free water, while filtering particulate from diesel fuel. Our **Aquacon**<sup>®</sup> AD Series products have over a 30 year history of proven application success and is ideal for use in fuel polishing.

- Removes particulate and water contaminants in fuels to meet stringent downstream ISO 4406, ASTM D975 and EN 590:2009 cleanliness standards for both diesel or biodiesel fuels
- Filtration prevents damage to injectors
- Constricts flow when media reaches capacity
- For applications up to 5,000 gpm (22,730 lpm)



### Particle & Water Removal (Coalescing)

Water is the primary cause of pump and injector failures in diesel engines and can displace diesel fuel's lubricant coating on high precision injector components. Water can be introduced throughout the fuel delivery process. Parker DI Series coalescer and DSO Series separator work together to separate water and aid in removing water from diesel fuel.

- Removes water from bulk diesel fuel
- Meets stringent ASTM D975 and ISO 4406 fuel cleanliness standards
- Flow rates from 20 to 5,000 gpm (91 to 22,730 lpm)



## Condition Monitoring Solutions Fast and Reliable

In the past testing fuel quality has always been costly, time consuming and done in laboratories. Some tests can take days resulting in slow response to prevent poor quality fuel from contaminating components in expensive equipment. Although on-board filtration systems are in place to perform some filtration, these systems were not designed to deal with high contamination levels.

As a result, strain on these systems leads to frequent maintenance and even bypass of contaminants. Increasing costly downtime, repairs and/or replacements.

Hydraulic & Fuel Filtration Division's line of fuel condition monitoring solutions range from fixed on-line systems such as the (Velcon) Contaminant Analyzer (VCA®) and Integrated Particulate Monitor (IPM™) to portable in-field systems such as the icountACM20, icountFS, and icountBSplus. All are designed to provide reliable accurate results in a short amount of time.

The VCA is an online monitoring system with the capability of detecting solid and liquid contaminants and can be configured to shut off flow when contaminant levels exceed your defined threshold. In addition, the telemetry option allows for remote monitoring on a global scale via cellular network.

The icount particle analyzers are designed for monitoring and testing of solid contaminants. All products can be used as an on-line monitoring system or be completely portable while providing real-time or immediate results with the capability of storing test results.



### Fuel Condition Monitoring

Parker HFFD offers various unique tools that will allow monitoring of diesel fuel quality throughout the distribution process, and through custody transfers with the correct blend of products, from disposable test kits to real-time precision instrumentation that measures particulate and water contamination simultaneously.

- **Contaminant Analyzer for Diesel (VCA®-D) is a military grade in-line full flow sensor system that simultaneously detects and differentiates between solid particulates and water contaminants in real time. The VCA-D detects pipe scales, particulates and water from truck pipelines, dirt and water from storage**
- **icountACM20, icountBSplus, icountFS and IPM™ are portable and online particle counters with proven laser detection technology**

# Primary Markets



## Mining

Today's electronically controlled diesel engines utilize the latest high pressure common rail systems that require pressures approaching 40,000 psi (2,758 bar) with injection nozzle sizes down to 2 microns. Meeting downstream ISO 4406 Cleanliness Standards for bulk fuel storage, dispensing, and during transfer can be challenging. HFF offers the filtration and process fuel monitoring technologies that extend equipment uptime and assures clean dry fuel.



## Retail

Retailers rely on their fuel suppliers to provide quality fuels that meet regulatory and engine manufacture requirements. Nevertheless, fuel stored and transported can acquire particulate and water contaminants that lower the quality below required specifications. HFF's filtration and separation solutions are designed to remove these contaminants and return fuel quality to desired levels.



## Refinery/Terminals

In the process of refining, storing in terminals and distributing bulk diesel fuel, contaminants such as abrasive silica, pipe scale and water are commonly introduced. As fuel is transported, it can quickly deteriorate fuel quality below ISO 4406 Cleanliness Standards required for use in today's diesel engines. Our filtration and separation solutions are designed to remove contaminants so the fuel supplied to customers meet or exceed original manufacturer required specifications.



## Transportation

Fuel is the number one operating cost for transportation fleets. Poor fuel quality directly affects maintenance cost, fuel expenditure, fuel efficiency and overall operating costs. From monitoring the quality of the fuel source to ensuring engines utilize fuels that meet ISO 4406 Cleanliness Standards, we provides solutions to help manage and meet your diesel fuel needs.



## Power Generation

Diesel powered plants require large fuel storage reservoirs and tank farms that must be available on demand. Our filtration and separation products are used to remove particulate and water and to ensure that fuel quality meets engine ISO Cleanliness Standards in order to assure reliability.

## CLEANDiesel®

Diesel and Biodiesel fuels may leave a refinery clean, but fuel quality can vary at the time it is dispensed due to contamination accumulated during transport and storage. Operators and engine manufacturers report that the majority of engine issues are due to dirt and/or water in the fuel. As diesel engines adopt more efficient High Pressure Common Rail (HPCR) systems, demands for removal of abrasive particles smaller than 6 microns are rapidly becoming a standard. Clean diesel fuel plays an important role in reducing maintenance and overall operating cost.

For over 60 years, Parker HFFD has supplied filters for fuel conditioning for applications from 5 gpm (23 lpm) to more than 5,000 gpm (22,730 lpm). Our proven bulk fuel handling experience in combination with the world's largest indoor fuel lab have allowed us to develop a range of high quality products to meet the most stringent diesel and biodiesel fuel market needs.

Image courtesy of APR Energy PLC

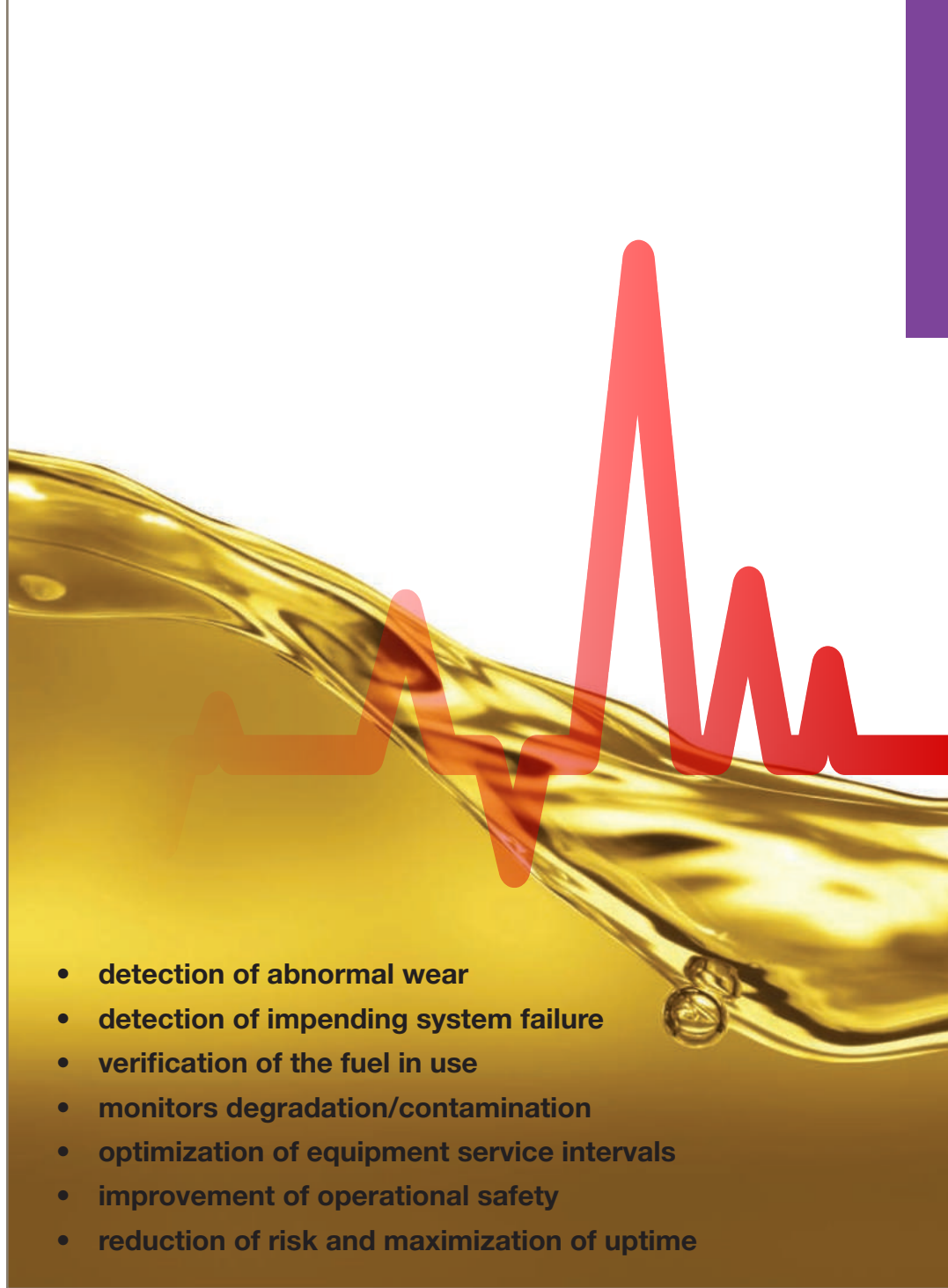

- detection of abnormal wear
- detection of impending system failure
- verification of the fuel in use
- monitors degradation/contamination
- optimization of equipment service intervals
- improvement of operational safety
- reduction of risk and maximization of uptime

## Diagnostic

Monitors, Detects, Alerts

---



# VCA®

## Velcon Contaminant Analyzer

### Simultaneous Detection of Solid and Water Contaminants at Full-Flow

The VCA system with a proper filtration system can provide assurance that the fueling system receives, maintains, and dispenses fuel that meets ASTM D975 and ISO 4406 cleanliness levels.

As a “full-flow” analyzer, the VCA mounts within a fuel delivery system thereby providing a true representation of the pipeline contents. The VCA analyzes fuel at varying flow rates but it can also analyze fuel at rates higher than 1000 gallons per minute through a 3 or 4-inch pipeline (contact Parker for other sizes).

The VCA uses two separate sensor technologies to consistently differentiate between water and solid contaminants.

The VCA analyzes the contents of flowing fuel in a pipeline approximately 600 times a second, and outputs an averaged result every two seconds in mg/l, ppm, and a representative ISO 4406 code.

The VCA is an ideal tool to either measure the quality of fuel at receipt, assuring agreed upon cleanliness specification are met, or at dispensing points. The VCA provides data to reassure the user that fuel cleanliness is within limits, and where not, it can be set to alarm or signal delivery system shutdown.



VCA - U.S. Patent No. 7,518,719  
VCA-CV - U.S. Patent No. 8,498,750

### Features and Benefits

- Ability to simultaneously differentiate between free water and solid particulates allows for a greater diagnostic accuracy of contamination sources
- Fuel quality accountability upon receipt with record of fuel quality at dispensing point
- System alarm or relay signal to shutdown control when fuel contaminant level is exceeded
- Reduce equipment downtime by preventing particulate and water from entering fuel storage
- Fuel system peace of mind with real-time constant monitoring of fuel condition
- Fully compliant with EI 1598 Second Edition
- Flow sensor operates VCA® only during fueling (US Patent No. 7,518,719)
- Full flow analysis – no sampling errors
- Isokinetic compliance
- Minimal pressure loss
- Fouling resistant windows
- Real-time PC-based graphical user interface for data viewing/capturing
- Real-time RS-232 data stream to tie into data management systems (optional)
- Easy installation cable/wiring
- Optional on-line data viewing/storage system



## Specifications

- Contaminant Measurement/Standard
  - Particulate Contaminant
    - mg/l (milligrams per liter)
    - ISO 4406 Reference Codes
  - Water Contaminant
    - ppm (parts per million)
- Mechanical
  - Pressure Rating: 150 psi (10 bar)
  - Flange Class: ANSI 150
  - Wetted Materials: Powder Coated Steel, Stainless Steel, and Glass
- Electrical
  - Configurable Output Control Alarm Relay
  - Certification: Class 1 Zone 2, IP65, NEMA 4x
  - Cable Length: 15 ft (4.57 m)
  - Requirements: 12-36VDC 4A or 110-240VAC
  - Control Box Dimensions: 12"W x 16"H x 8"D
- Data Output
  - PC-Based Interface
    - Graphical User Interface (GUI)
    - Real-Time Data
    - Scalable data graphing
  - Local Data Storage
    - On-Board Data Logging (CSV)
    - User Configurable Alarms (Current & Average Values)
    - Downloadable to USB Storage Device
  - Additional SCADA integration (optional)

## Models Available

Part Number	Description
VCA-D3	VCA for 3" diameter
VCA-D4	VCA for 4" diameter

## Dimensions

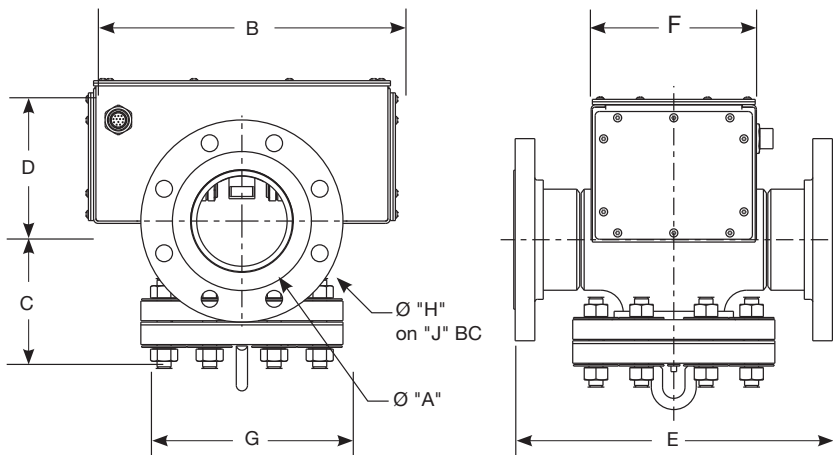

Per Fueling Session:  
E-mail Field Data Reporting  
(with cellular telemetry option)

Pipe Diameter (in.)	Dimensions in (mm)								
	A	B	C	D	E	F	G	H	J
3	3 (76)	13 11/16 (348)	4 3/4 (121)	5 11/16 (144)	13 5/8 (346)	8 1/8 (206)	7 1/2 (191)	3/4 (19)	6 (152)
4	4 (102)	13 11/16 (348)	5 1/2 (140)	6 1/4 (159)	14 1/4 (362)	7 3/8 (187)	9 (229)	3/4 (19)	7 1/2 (191)

Dimensions shown are for estimating purposes only. For exact dimensional detail, please contact Hydraulic & Fuel Filtration Division or your local HFF representative.

# icountACM20

## icount Aviation Condition Monitoring with Diesel Fuel Compatability

### State-of-the-Art Fuel Contamination Monitoring

The icountACM20 Portable Particle Counter was developed from existing technology for monitoring contamination in AVTur and other hydrocarbon fuels, in accordance with Energy Institute (EI) Method IP 564.

In addition, the ACM can also be used to monitor fuels from existing sampling points in locations from refineries, pipelines, distribution terminals, fuel supply storage.

### Features and Benefits

- 2 minutes test time
- Optical scanning analysis and measurement of actual particles and inference to water presence
- Primary outputs: 4, 6, 14, 21, 25, 30 $\mu$  counts per ml
- % Volume distribution, via graphical display on handset and printout
- ISO 7-22 in accordance with ISO 4406-1999
- 32 Character two line dot matrix LCD. Full alphanumeric entry facility on keypad
- Access up to 300 saved test
- Calibration in accordance with Parker Calibration Procedure CM20-N, which complies to ISO11171:1999, Clause 6 (Omitting Annex F)
- Re-calibration every 12 months by a dedicated Parker Service Center
- 420 bar max. working pressure
- +5° C to +80° C
- Interface via RS232 (USB serial cable to RS232 option available)
- On-board rear mounted pump for lab sampling
- On-board battery and carry case with wheels (13 kg total weight)
- 12v DC input, 6 "D" cell batteries or rechargeable battery pack
- Integrated 16 column printer for hard copy data
- Complies with all relevant EC declarations of conformity
- Integrated Mounted Pump:
  - Powered directly from ACM20
  - Direct sampling from fuel sample bottles or tank via 3 meter inlet suction tube
  - Incorporated double speed flush and test sequence
  - Managed flow rate/correct volume sample as per IP 564 test method



### Applications

- Fuel Testing Laboratories - DEFSTAN 91-91 Issue 6
- Distribution Terminals/Hubs: use on receipt and outbound supply. Also provide checks for filtration performance, tank cleanliness and product quality
- Storage: reduce settling time by monitoring to determine if dispersed contamination are below acceptable levels
- Airport Fuel Farm: monitoring of fuels into storage, through fuel farm, hydrant system and during uplift into wing
- Oil and Gas Platforms: monitor filtration performance, system cleanliness and quality of delivered product



# icountACM20

## Specifications

- **Construction:** ABS structural foam and injection moulded case  
Hand-held display - ABS  
Keypad fluoro-silicone rubber
- **Mechanical Components:** Brass, plated steel, stainless steel and aluminium
- **Seals:** Fluorocarbon
- **Hoses:** Nylon (Kevlar braided microbore). Stainless steel armoured ends
- **Flow Rate:** 25 - 28ml/min (dictated by CMP) 100ml/min with additional flush button
- **Fluid Compatibility:** Hydrocarbon Fuel, Mineral Oil. For other fluids consult Parker
- **Fuse:** 1.25 amp fast blow fuse included for overload protection (spare supplied)
- **icountACM20 Technology:** Patented flow cell, light obscuration
- **Repeatability/Accuracy:** As per or better than ISO 11171
- **Coincidence:** 40,000 particles per ml
- **Viscosity Range:** 1 -100 centistokes
- **icountACM20 Weight:** 17.6 lbs.
- **Monitor Carrying Case:** Astra Board case
- **Carrying Case Weight:** 11 lbs.

## icountACM20 - Rear View

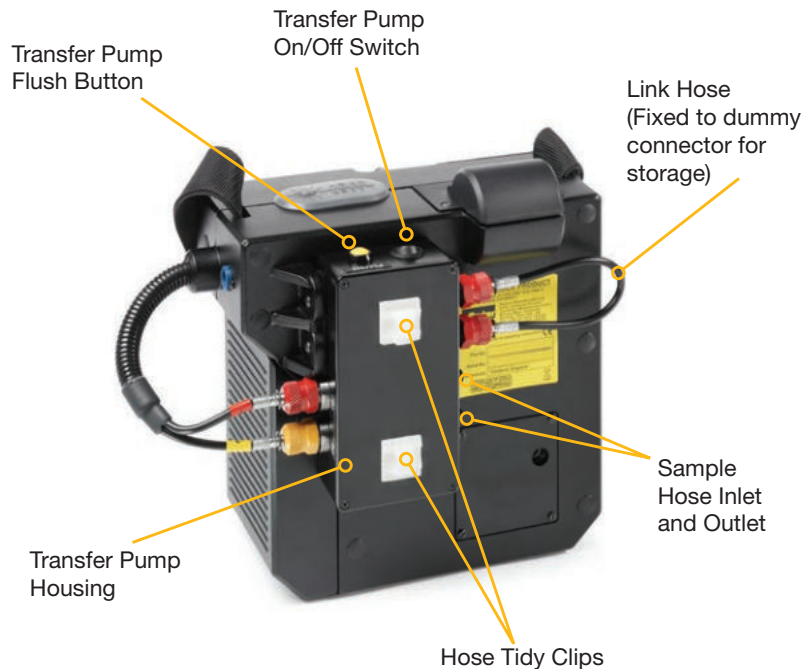

Input Power Socket (note that you will have to remove the plastic dust cap to access the 12Vdc power socket)

A fast blow 1.25A fuse and the RS232 connection are located behind the removable cover plate. The RS232 interface is provided to download all test data stored in the instrument.



### Field Monitoring

For use in non-hazardous areas, the icountACM20 is designed for online sampling of hydrocarbon fuels, utilizing existing “quick connect” sampling points such as the Millipore Adaptor.

# icountACM20

## Models Available

Part Number	Description
ACM202024US ACM202024UK ACM202024EUR	icountACM20 Portable Particle Counter with US,UK or EUR Plug

## Standard Components

Qty.	Description
1	1 meter process cable
1	Parsmart downloader software
1	icountACM20 transit Case
1	Vapour/waste bottle assembly
1	Throttle kit
1	Millipore adaptor kit
1	Re-chargeable battery pack
1	UK power supply

Qty.	Description
1	US power supply
1	Euro power supply
1	UK Offline kit
1	Euro Offline kit
1	US Offline kit
1	500ml verification fluid
1	Printer reel (x5)
1	Printer ribbon (x1)

## Optional Accessories

Part Number	Description		Part Number	Description	
ACC6NE008	UK Power Supply		ACC6NE023	UK Battery Charger	
ACC6NE009	EUR Power Supply		ACC6NE024	EUR Battery Charger	
ACC6NE010	US Power Supply		ACC6NE025	US Battery Charger	
ACC6ND000	1m Process Cable Assembly		ACC6NW003	Waste Bottle	
ACC6NE027	2m Process Cable Assembly		ACC6NE013	Re-Chargeable Battery Pack Assembly	
ACC6NE029	Throttle Kit		ACC6NE006	Downloadable Software	
ACC6NE015	Printer Paper 5 Rolls		ACC6NE019	Carrying Case for ACM202024	
SERMISC067	500ml Verification Fluid		ACC6NE014	Printer Ribbon	

# icountFS

## icount Fuel Sampler

### Portable Condition Monitoring for Fuel Systems

The icountFS (iFS) is an innovative solution to the challenge of measuring the quality of hydrocarbon fuels in many different applications: from renewable energy, marine and offshore, to manufacturing, mobile, agriculture, military and aerospace.

Compact, lightweight and robust, the truly portable iFS makes field analysis simple, quick and easy.

Able to sample directly from a barrel, vehicle fuel tank or from pipes in a fuel system with the addition of a pressure reducing adaptor; the iFS is undoubtedly the most adaptable contamination service tool available today.



Powerful and easy to use



Lightweight and portable

The system is completely self contained, with laser detection particle counter, battery and pump plus memory with web page generator for data download onto any PC or laptop - combined into a single unit. The iFS uses Parker's proven laser detection technology, which delivers precise, repeatable, reproducible results, in real time detection of both particulates, down to 4 microns (c) and dissolved water.

Just as importantly, the iFS has been developed to offer a wealth of features, combined with simplicity and ease of use, at a cost that is far lower than competing systems, and which fits within most maintenance budgets. Fluid viscosity as high as 300cSt (usable range) will be able to pass through the detector at the proper flow rate.

### Features and Benefits

- Quick connections for testing fluid online and offline
- Reporting Standards ISO4406:1999, NAS1638 display in high intensity LED format
- Data Storage up to 250,000 test points of information
- Compact, lightweight and robust, truly portable iFS makes field analysis simple, quick and easy
- Able to sample directly from a barrel and vehicle fuel tank or from an online fueling system with the addition of a pressure reducing adaptor
- Completely self contained, with laser detection particle counter (icountPD), rechargeable battery and flow management pump
- No special software needed
- Embedded web page generator for data downloading. Connect via Ethernet (universal RJ45) or WiFi to PC, laptop, or smartphone.
- Fast detection of the presence of contamination with a sampling period from 5 seconds to 999 seconds

# icountFS

The iFS quality condition monitor for hydrocarbon fuels uses advanced technology to produce extremely repeatable results. At the heart of the system is a sophisticated laser detector, using a light obscuration flow cell, providing continuous measurement of fluid flow passing through a sample tube.

Measurements are taken every second as standard, although measurement intervals and test period can be defined by the user, with results being reported immediately and updated in real time. Data is displayed on a built-in LED digital display and can also be stored for subsequent upload via the embedded icount's web page interface connecting through an RJ45 cable.



## Dimensions

in. (mm)

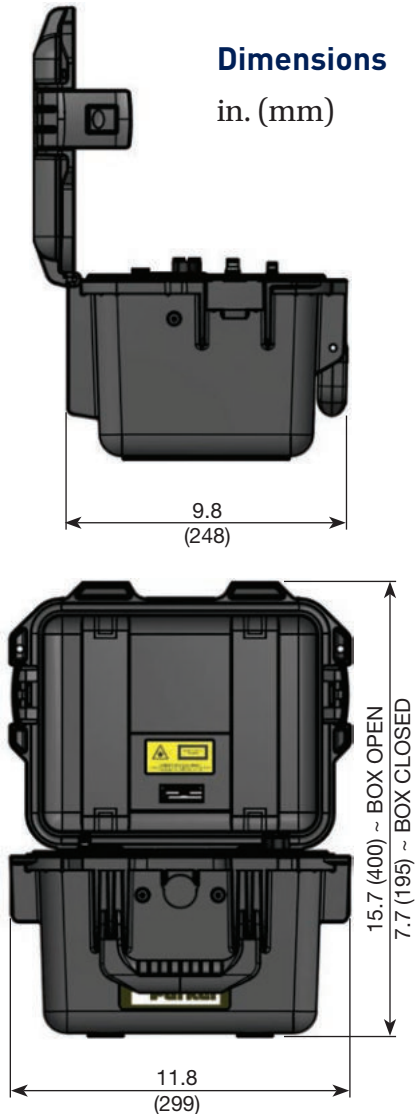

# icountFS

## Models Available

Part Number	Fluid Type	Calibration	Connection	Option
IFS3210US	Fuel	MTD	Offline	None
IFS3220US	Fuel	MTD	On line	None
IFS3221US	Fuel	MTD	On line	WiFi

## Optional Accessories

Part Number	Description		Part Number	Description	
ACC6NE000	Sample Hose Kit (1m & 3m)		ACC6NK001	1 pair Sample Bottles	
ACC6NE034	1m Hose		ACC6ND001	10 pair Sample Bottles	
			ACC6NE002	50 pair Sample Bottles	
ACC6NN046	On-line Probe		SERMISC067	500ml Verification Fluid	
ACC6NE003	1m Extension Hose & Couplings Set - 2 Hoses		ACC6NE008	UK Power Supply	
ACC6NN003	2m Hose Set - 2 Hoses		ACC6NE009	EUR Power Supply	
ACC6NN005	5m Hose Set - 2 Hoses		ACC6NE010	US Power Supply	

# icountBSplus

## icount Bottle Sampler

### The Benchtop Solution to Fluid Contamination Bottle Sampling

The revolutionary icountBSplus is an advanced, fully contained bottle sampling system that ensures fast, accurate and repeatable detection of contamination in diesel fuels. Compact and portable, the icountBSplus is ideal for use in the laboratory, on-line or off-line applications.

The system is fully accredited to all particle counting standards - ISO, NAS, AS and GOST - including the latest ISO medium dust certification and is backed by Parker Hannifin's global customer support network. The icountBSplus uses proven laser particle detection technology, with intuitive touch screen control, integrated long life rechargeable battery and a robust easy to clean enclosure, to deliver exceptional product quality and performance.

The icountBSplus is quick to setup and use, delivers rapid test results and offers a wide range of features to help you improve the reliability, productivity and profitability of your production equipment.



### Features and Benefits

- Easy access wake up switch
- Built-in printer
- High resolution backlit touch screen
- Sample preparation chamber
- Stylus pen stored safely in base
- Robust outer panel design
- Low cost solution for monitoring fluid life and reducing machine downtime
- Easy to setup and use this CE compliant instrument
- Selectable 12 language instruction manual menu
- Optional on-line fluid measurement capability
- Independent monitoring of contamination
- Calibration to ISO procedures
- 8 fixed channel size analysis
- Integrated relative humidity moisture sensor
- Selectable test sample sizes: 25, 50, 75 and 100ml
- Selectable flush sample sizes: 10, 15, 20, 25, 50, 75 & 100ml
- Selectable number of samples taken in one time: 1, 2, 3, 4 or 5 tests
- Mineral fluid/fuel compatible construction
- Percentage saturation reporting (for the moisture sensor option)
- Testing capability of up to 500 continuous tests (override auto warning option available)
- Data exporting method to USB (in XML format)
- Modular design for easy servicing
- On-board high quality pump and motor configuration
- High resolution color touch-screen panel and the
- Integrated printer (selectable on/off feature)
- Self-diagnostic software
- Power-saving sleep mode with integrated wake up/power button
- On and off line pressure capability
- Quick sample bottle analysis with variable test time options from 15 seconds and volume capacities from 25ml
- On-board compressor and 'shop' air capability
- On-board thermal printer
- Environmentally controlled front loading bottle chamber
- Selectable 12-language instruction manual menu
- Analysis of fluid moisture and temperature capability
- Repeatable and re-producible result performance to ISO4406:1999, NAS1638 AS4509E and GOST 17216:2001 (Differential and Cumulative) particle count distributions
- icountBSplus has the capability for on-line fluid measurement configuration as well as off-line fluid sampling
- Design concept allowing for portability. DC and rechargeable battery pack power option built in
- CE compliant
- Fluid resistant touch type screen panel
- 500 test memory (fully downloadable)

# icountBSplus

## Specifications

<b>Principle of Operation</b>	Laser based light obscuration
<b>Dimensions</b>	H=20.9" x W=7.48" (8.27" Door) x D=16.1"
<b>Weight</b>	31 lb. (14kg)
<b>Mechanical Composition</b>	Stainless steel 316, plated mild steel and aluminum
<b>Plastics Composition</b>	Precision polyurethane RIM moldings and ABS plastic
<b>Environmental Operating Temperature (Tested)</b>	41°F to 140°F (+5°C to +60°C)
<b>Operating RH Range</b>	20 - 85% [Tested at 86°F (30°C), no condensation]
<b>Storage Temperature</b>	40°F to 194°F (4°C to 90°C)
<b>Storage RH Range</b>	10 - 90% (Tested at 30°C, no condensation)
<b>Channel Sizes</b>	MTD - >4μ(c), >6μ(c), >14μ(c), >21μ(c), >38μ(c), >70μ(c), ACFTD - >2μ, >5μ, >15μ, >25μ, >50μ, >100μ
<b>Analysis Range</b>	ISO 7 to 21, NAS 0 to 12
<b>Contamination Standards</b>	MTD - ISO 4406:1999 & NAS 1638; ACFTD - ISO 4406:1987, ISO 4406:1991, NAS 1638, and AS4059 Rev E <i>For further contamination standards consult Parker</i>
<b>Calibration Standard</b>	ISO MTD and ACFTD calibration to traceable ISO Standards. <i>Contact Parker for further details</i>
<b>Fluid Management</b>	Maximum single sample = 100ml, Minimum single sample = 10ml
<b>Possible Test Configurations</b>	User selectable from single test up to 5 tests per run (eg. 1 x 100ml up to 5 x 50ml per run)
<b>Pre- Test Flush Volume</b>	Minimum = 10ml, Maximum = 100ml
<b>Viscosity Range</b>	5 to 400 cSt
<b>Fluid Compatibility</b>	Mineral oils, petroleum and hydrocarbon based fluids. For all other fluids, consult factory.
<b>Sample Bottle Size</b>	No specific bottle required. Maximum size = 2.95" (Dia.) x 5.90" (H). Maximum volume = 250 ml
<b>Memory Storage</b>	500 tests (capacity warning after 450 tests)
<b>Output Display</b>	Backlight 256 color STN transmissive
<b>Output Display Resolution</b>	320 x 3 (RGB) (H) x 240 (W) dots
<b>Display Active Area</b>	115 (H) x 86 (W) mm
<b>Data Input</b>	Icon driven resistive touch screen
<b>Printer</b>	Thermal dot- line printing
<b>Printer Paper</b>	Ø50mm (57mm x 25mm)
<b>Test Certification</b>	Calibration & Certificate of Conformity
<b>Power Supply</b>	DC output - 12V @ 6.60Amps, 80 watts max. AC input - 100 to 240V @ 1.2Amps (50-60Hz), AC input - 100 to 240V @ 1.2Amps (50-60Hz)
<b>Battery Power</b>	2 hours (recommended to be fully charged every 3 months)
<b>Battery Stand By Time</b>	1 month (then 1 hour of operation)
<b>Battery Fuse</b>	6.3 Amps (anti-surge)
<b>Air Pressure Source</b>	50 psi (3.5 bar) internal mini- compressor or 101 psi (7 bar) shop air

# icountBSplus

## Specifications

- 1 Emergency air release
- 2 4mm vapour release port
- 3 6mm oil drain port
- 4 External air supply
- 5 External on-line oil supply (if fitted)
- 6 Long life Lithium Ion battery
- 7 Mains on/off and power socket
- 8 USB connections A and B
- 9 Ventilation fan (DO NOT BLOCK)

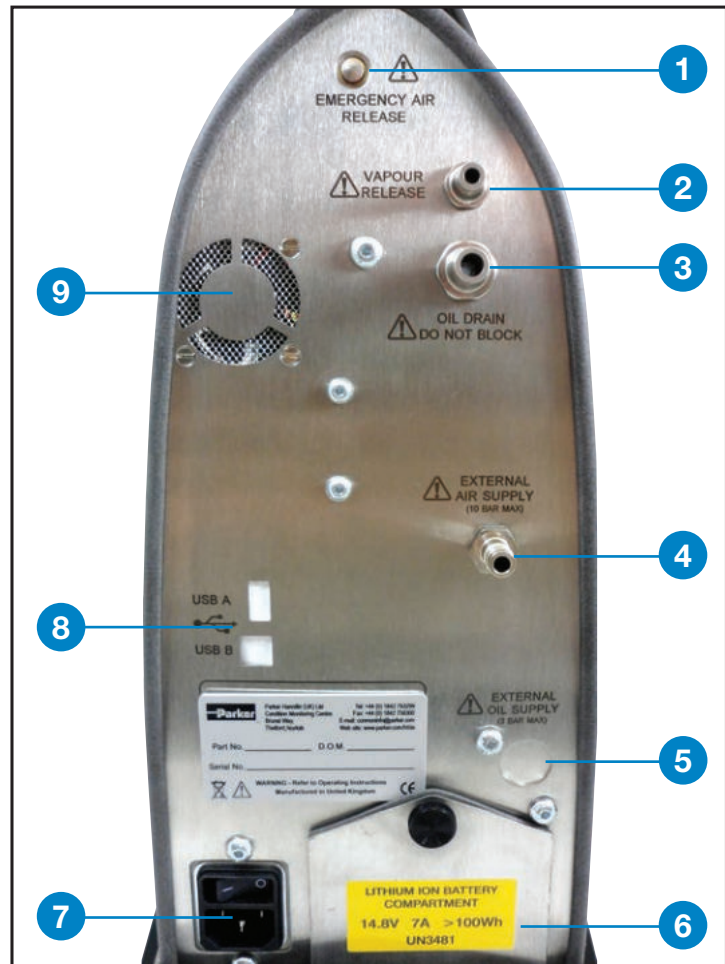

**Dimensions**  
in. (mm)

# icountBSplus

## Sample handling and preparation

### Bottle cleanliness

Bottles should have sealing screw caps, with both parts cleaned to a suitable level in accordance with ISO3722. Standard Parker Hannifin bottles (supplied in pairs as part number ACC6NW001) are supplied clean to ISO 13/11 or better in a Class 10,000 Clean Room. The bottle should remain capped until the time of sample filling and be re-capped immediately afterwards.

### Sample mixing

Sedimentation of contaminant in a sample will occur, the rate of which is dependent upon both the fluid and particle characteristics.

Where facilities are available, mixing can be achieved using 'paint shakers' and/or an ultrasonic bath. Take care when using ultrasonic baths to avoid distortion of the result by prolonged use, which could cause the breakdown of contaminants.

Bottle samples can be stirred by swirling and tumbling by hand, end-over-end. Samples should be analyzed, without delay, once agitated.

### Results

The first result from a bottle sample should be disregarded, as it could be distorted by fluid from a previous sample. Samples from different parts of a system will give different results.

Consideration should be given to what monitoring is desired and where to extract samples from for suitable trend monitoring to be performed.

It is important that whatever practices you adopt; you must perform them consistently.

Part Number	Description	
IBS3100	icountBSplus Advanced Bottle Sampler Testing	
ACC6NW001	250ml Sample Bottle 2-Pack	
ACC6NW002	250ml Sample Bottle (50) 2-Packs	
ACC6NW003	Vapor/Waste Bottle	
ACC6NW005	Printer Paper Reel	

Part Number	Description	
ACC6NW011	USB Memory Stick	
ACC6NW012	Manual on CD	
ACC6NW020	Transit Case	
SERMISC049	500ml Verification Fluid	
ACC6NW009	1m Waste Tube Clear	
ACC6NW010	1m Waste Tube Blue	

# Integrated Particulate Monitor

## IPM™ Series

### Most Up-to-Date Technology in Solid Particle Contamination Analysis

The IPM is a compact, permanently mounted laser based particle detector module that provides a cost-effective solution to fluid management and contamination control.

The IPM measures particle contamination continuously utilizing the Parker icountPD (IPD), updates the display, and outputs ISO code values to an RS-232, CAN bus or Cellular (GSM) Data Acquisition Module.

The laser based, leading edge technology is a cost effective market solution to fluid management and contamination control.



### Principles of operation

The IPM measures particle contamination continuously updates the display, output options and limit relay every second, and does not perform a “one-off” test. This means that even if the Measurement Period is set to 60 seconds, the display, output and limit relay all report the presence of dirt in the oil in just a few seconds—it does not wait until the end of the Measurement Period before reporting the result.

The IPM has just one setting to control the accuracy, stability and sensitivity of the measurements and that is the “Measurement Period.” This can be set from five seconds to 180 seconds. The longer the Measurement Period, the more contaminant is measured, averaging out any spikes seen on a smaller sample. The shorter the Measurement Period the more sensitive the IPM is to variation of contaminant

level, but also the performance on clean systems can be reduced. Thus, the user can select how sensitive the IPM is to spikes of contaminant, and how quickly it responds to contamination levels above the set point (“limits”).

The Measurement Period is factory set to 60 seconds, updated on a second by second basis, giving an effectively continuous readout of the level of contamination.

### Features and Benefits

- Independent online monitoring of system contamination trends
- Cost effective solution in monitoring fuel cleanliness and reducing machine downtime
- LCD display with alarm output warnings
- Continuous performance for dependable analysis
- Diesel, kerosene fuel compatible construction
- Self-diagnostic software
- PC/PLC integration technology using Data Acquisition RS-232 or CAN bus output
- Reporting interval through visual display, RS-232, CAN bus or Cellular data acquisition module

### Specifications

- Diagnostic self-check start-up time 5 seconds after power up
- Reporting interval through visual display, CAN bus, Serial, or Cellular
- Digital LED display update time every second
- Principle of operation Laser diode optical detection of actual particulates
- Reporting codes ISO 7-12, NAS 0-12, (AS 00-12 contact Parker)
- Calibration by recognized on-line methods, confirmed by the relevant ISO procedures
- Calibration recommendation 12 months
- Performance +/- 1 ISO Code (dependant on stability of flow)
- Reproducibility/Repeatability better than 1 ISO code
- Hydraulic connection M16x2 hydraulic test points
- Optimum flow range through the device is approximately 60 ml/min
- Viscosity range 10 to 500 cSt
- Operating fluid: 32°F to 185°F (0°C to 85°C)
- Working pressure 30 to 100 psi (2 to 7 bar)



# Integrated Particulate Monitor

## IPM-100 Series

### Models Available

Part Number	Description
IPM-110	CAN bus or RS-232 to Customer Control System, No LCD Display
IPM-120	MOD bus over TCP/IP, No LCD Display

### Standard Components

Qty.	Description
1	IPM-100 Series Unit Enclosure
1	Installation and Operation Manual
1	Sampling Hose Set, 5 m long, P/N ACC6NN005
1	Mounting Hardware
1	Enclosure Lid Key



### Dimensions

in. (mm)

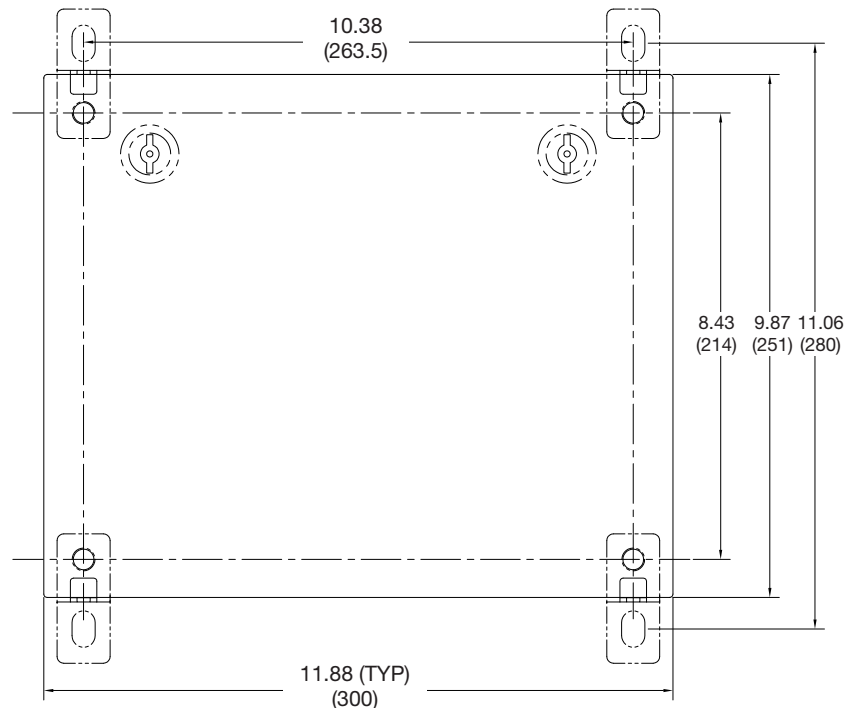

# Flow Differential Pressure Module

## FDPM®

### Automatic Calculation of Corrected Differential Pressure for Varying Flow Rates

The FDPM® MK II builds on its field tested predecessor. Designed to comply with the requirements of industry standards such as ATA 103 and JIG Guidelines, the FDPM® MK II eliminates this normally complicated calculation by automatically calculating the condition of the filters inside a vessel based on the inputs from differential pressure and flow-rate sensors. FDPM® MK II can be used with either mobile or stationary equipment.



### Features and Benefits

- Designed with A4A 103 & JIG Guidelines data collection requirements in mind
- Removes human judgment regarding condition of filters
- Simplified for the refueling operator yet highly configurable by the fuel master
- Interactive touch screen display enables easy operation even for gloved users
- Condition based alarms can be set to halt the fueling operation
- Intelligent detection of sudden increases or decreases in differential pressure
- Security codes prevent resetting of key values by unauthorized personnel
- Over 3 years of data logging automatically stored via a MicroSD card

### Interactive Touch Screen Display

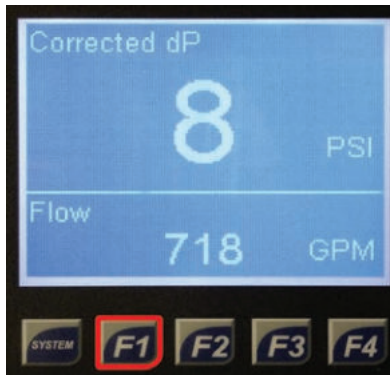

F1- Corrected dP and Flow Information



F2- Tabulated Averaged and Maximum Values for the Refueling Session

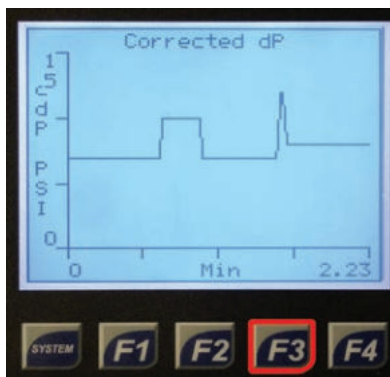

F3- Real-time Corrected dP Chart

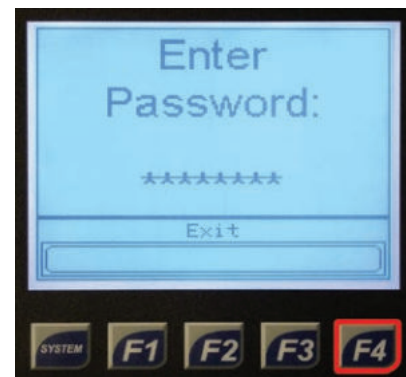

F4- Supervisor Menu

### Display Outputs

- Corrected DP
- Actual DP
- Flow Rate
- Peak corrected and actual DP
- DP rise or drop alarm

# Flow Differential Pressure Module

## Specifications

### Inputs

- 12 -24VDC, 300 mA (Power), AC/DC Converter
- Flow Rate Input: 0-8 Volts Minimum (24 Volts Max)
- One of the Following:
  - 2 Pressure Transducers: 4 -20 mA
  - 1 Differential Pressure Transducer: 4 -20 mA

### Deadman Switching Relay

- 3A @250 VAC Max

### Weight

- 4 pounds (1.8 kg)

### Safety/Compliance

- IP 65
- NEMA 4X
- ATEX Directive Class 1 Zone 2 Group D

### Visual Outputs/Indicators

- Interactive Touch Screen
- Daylight Readable
- Optional Amber Light: Warning Indicator
- Optional Red Light: Critical Indicator
- Corrected Differential Pressure
- Actual Differential Pressure
- Flow Rate
- Peak Corrected and Actual Differential Pressure
- Real-Time Corrected Differential Pressure Charting
- Sudden DP Rise or Drop Alarm

### Data Logging

- Removable Micro SD Card (Included)
- >36 Months Data (MS Excel Compatible)
- 60 Second Logging Interval (User Configurable)
- Data Download via USB (Optional)

### Data Outputs

- RS232 (ASCII Serial Data Stream)

### Measurement Units

- psi, US gpm
- bar, lpm

### Alarm triggers

- Warning Alarms (Amber Light)
  - 12 psi or 0.8 bar (User Configurable)
  - Pressure Greater than the System Rating
  - Change in DP (User Configurable)
- Critical Alarms (Red Light)
  - External Switch Relay (Deadman)
  - 15 psi or 1.0 bar (User Configurable)
  - Change in DP (User Configurable)

## Dimensions

in. (mm)

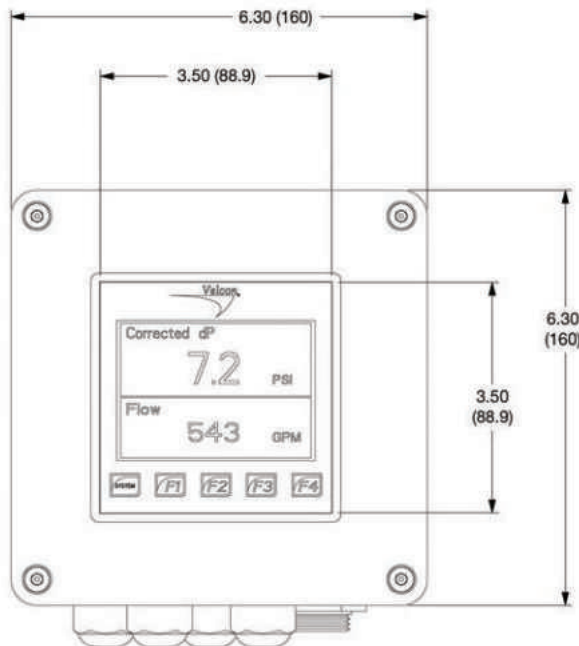

Front View

## Ordering Information

Part Numbers	Description
FDPM-MKII	FDPM Unit
764X021	Pressure Transducers



## Options

- Pressure Sensors
  - 2x Pressure Transducers - Class I Division I
  - 1x Differential Pressure Transducers - Class I Division I
  - 1x Differential Pressure Transducers - IP65 NEMA 4

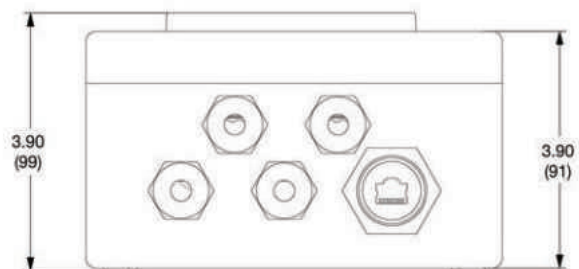

Bottom View

# icountPD<sup>®</sup>

## icount Particle Detector

The Most Up-to-Date Technology in Solid Particle Detection

The design dynamics, attention to detail, and small size of the permanently mounted, on-line particle detector brings a truly innovative product to all industry. The laser based, leading-edge technology is a cost effective market solution to fluid management and contamination control.

### 3 Versions Available

**Standard icountPD** is designed for test stand, flushing skids, filter carts and other industrial applications.

**icountPDR** is designed for mobile equipment or any outside use other than hazardous environment.

**icountPDZ** is intended for applications that require a Zone II safety such as off-shore platforms or any other hazardous environment.

For Zone I applications the standard icountPD can be used within a NEMA7 enclosure.



### Features and Benefits

- Independent monitoring of system contamination trends.
- Early warning LED or digital display indicators for Low, Medium and High contamination levels.
- Cost effective solution in prolonging fluid life and reducing machine downtime.
- Visual indicators with power and alarm output warnings.
- Continuous performance for dependable analysis.
- Hydraulic, phosphate ester & fuel fluid compatible construction.
- Self diagnostic software.
- Fully integrated PC/PLC integration technology such as: RS232 and 0-5 Volt, 4-20mA, and CANBUS J1939.



icountPD



icountPDR



icountPDZ

# icountPD<sup>®</sup>/icountPDR/icountPDZ

## Specifications

<b>Diagnostic self check start-up time</b>	5 seconds
<b>Measurement period</b>	5 to 180 seconds
<b>Reporting interval through RS232</b>	0 to 3600 seconds
<b>Digital LED display update time</b>	Every second
<b>Limit relay output</b>	Changes occur +/- 1 ISO code at set limit (Hysteresis ON) or customer set (Hysteresis OFF)
<b>4-20mA output signal</b>	Continuous
<b>Principle of operation</b>	Laser diode optical detection of actual particulates
<b>Reporting codes</b>	ISO 7 – 21, NAS 0 – 12, (AS 00 – 12 contact Parker) Icount will also report less than ISO 7, subject to the statistical uncertainty defined in ISO4406:1999, which is shown in the RS232, reporting results as appropriate e.g “>6”
<b>Calibration</b>	By recognized on-line methods, confirmed by the relevant International Standards Organization procedures
<b>Calibration recommendation</b>	12 months (24 months for icountPDZ)
<b>Performance</b>	+/- 1 ISO Code (dependant on stability of flow)
<b>Reproducibility / Repeatability</b>	Better than 1 ISO Code
<b>Power requirement</b>	Regulated 9 to 40Vdc
<b>Maximum current draw</b>	150mA
<b>Hydraulic connection</b>	icountPD: M16 x 2 hydraulic test points (5/8” BSF for aggressive version) icountPD Z2: Size: 066, Connection: EO 24 cone end
<b>Flow range through the device</b>	40 to 140 ml/min (optimum flow = 60ml/min)
<b>Online flow range via System 20 Inline Sensors</b>	Size 0 = 1.6 to 6.6 gpm (7.2 to 30 lpm); (optimum flow = 3.9 gpm (18 lpm)) Size 1 = 6.3 to 26.4 gpm (28.6 to 120 lpm); (optimum flow = 18.5 gpm (84 lpm)) Size 2 = 44.9 to 100 gpm (204.1 to 454 lpm); (optimum flow = 66 gpm (300 lpm))
<b>Required differential pressure across Inline Sensors</b>	5.8 psi (0.4 bar) minimum
<b>Viscosity range</b>	10 to 500 cSt, 1 to 500 cSt
<b>Temperature (icountPD and icountPDR)</b>	Operating environment: -4°F to +140°F (-20°C to +60°C) Storage: -40°F to +176°F (-40°C to +80°C) Operating fluid: +32°F to +185°F (0°C to +85°C)
<b>Temperature (icountPDZ)</b>	Operating environment: -22°F to +140°F (-30°C to +60°C) Storage: -40°F to +176°F (-40°C to +80°C) Operating fluid: +41°F to +176°F (+5°C to +80°C)
<b>Working pressure</b>	30 to 6,000 psi (2 to 420 bar)
<b>Operating humidity range</b>	5% RH to 100% RH
<b>Certification</b>	IP66 rated (icountPD), IP69K (icountPDZ) EMC/RFI – EN61000-6-2:2001(icountPD, PDR), EN6100-6-2:2005 (icountPDZ) EN61000-6-3:2001(icountPD, PDR), EN61000-6-3:2007 (icountPDZ)
<b>Materials</b>	Stainless Steel case construction (icountPDZ) Stainless Steel hydraulic block (icountPD and icountPDR) Fluorocarbon seals
<b>Dimensions</b>	icountPD: 7.2” x 6.1” x 3.4” (182mm x 155mm x 86mm) icountPDR: 4.52” x 7.01” x 4.53” (114.7mm x 178.8mm x 115mm) icountPDZ: 10.2” x 4.49” x 4.33” (260mm x 114mm x 110mm)
<b>Weight</b>	icountPD: 2.9 lbs. (1.3 kg), icountPDZ: 5.73 lbs. (2.6 kg)
<b>Default Settings</b>	See table on page 32

# icountPD<sup>®</sup>

## Dimensions/Installation

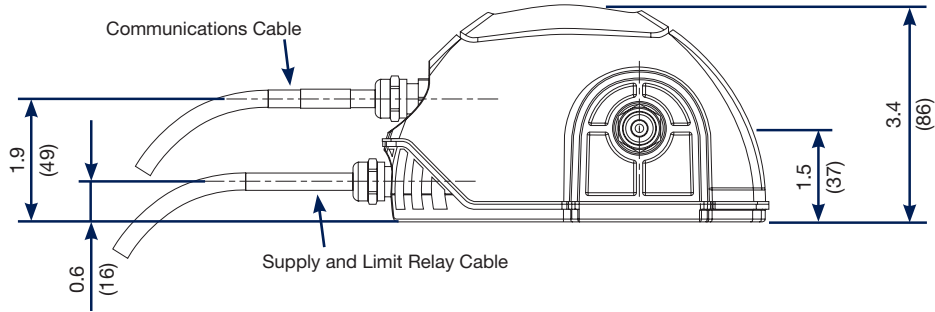
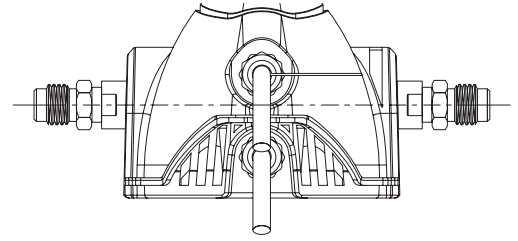

### Dimensions

in. (mm)

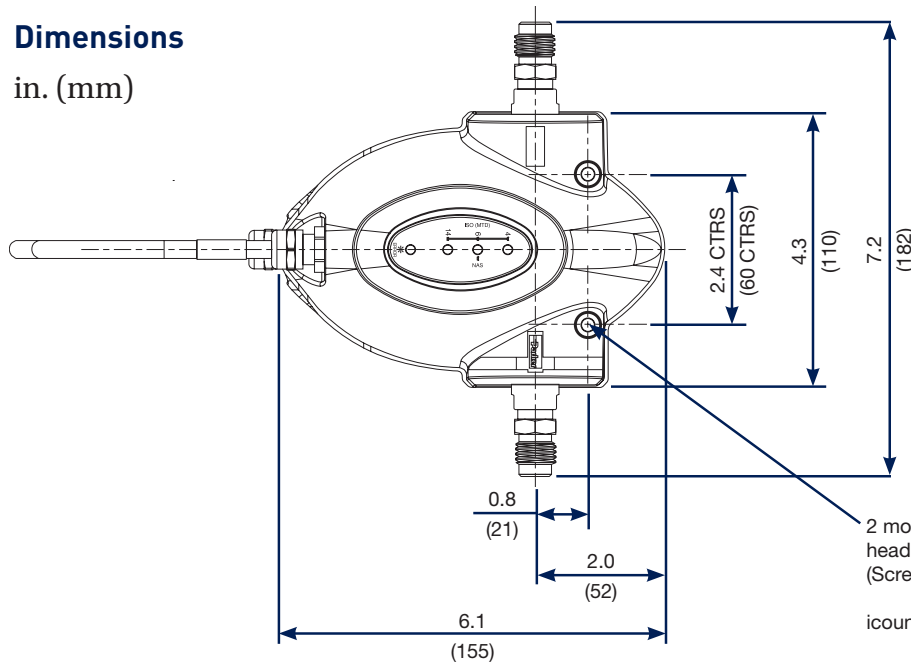

2 mounting locations to suit M5 socket head cap screw.  
(Screw pack supplied with icountPD)

icountPD flange thickness = 0.4" (10mm)

**Maximum Torque 5Nm**

### \*Limit Relay Wiring Instructions

NORMALLY OPEN  
NORMALLY CLOSED  
COMMON

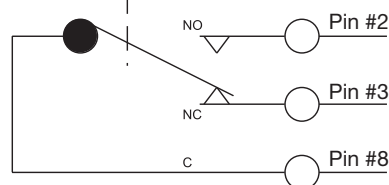

# icountPD<sup>®</sup>

## Variable mA Output Settings

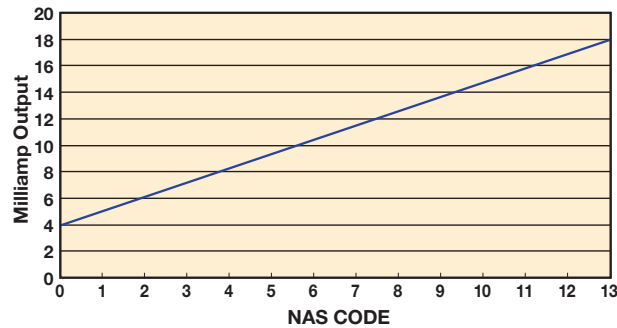
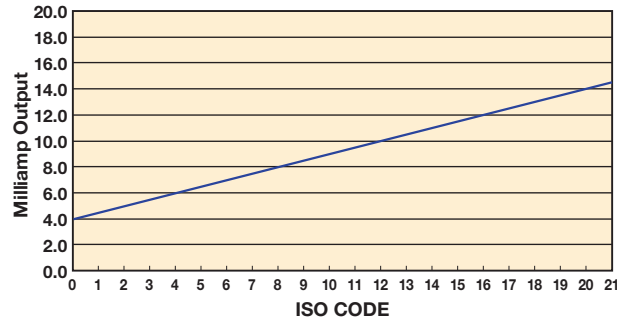

The following table can be used to equate the analog output for channels A, B, and C independently. Example: ISO code 12 is equal to 10mA.

mA	ISO	mA	NAS
4.0	0	4	00
4.5	1	5	0
5.0	2	6	1
5.5	3	7	2
6.0	4	8	3
6.5	5	9	4
7.0	6	10	5
7.5	7	11	6
8.0	8	12	7
8.5	9	13	8
9.0	10	14	9
9.5	11	15	10
10.0	12	16	11
10.5	13	17	12
11.0	14	18	**
11.5	15	19	**
12.0	16	20	ERROR
12.5	17		
13.0	18		
13.5	19		
14.0	20		
14.5	21		
15.0	**		
15.5	**		
16.0	**		
16.5	**		
17.0	**		
17.5	**		
18.0	**		
18.5	**		
19.0	OVERRANGE		
19.5	OVERRANGE		
20.0	ERROR		

### 4-20mA output settings

#### ISO Setting

mA current = (ISO Code / 2) + 4

eg. 10mA = (ISO 12 / 2) + 4

or

ISO Code = (mA current - 4) \* 2

eg. ISO 12 = (10mA - 4) \* 2

#### NAS Setting

mA current = NAS Code + 5

eg. 15mA = NAS 10 + 5

or

NAS Code = mA current - 5

eg. NAS 10 = 15mA - 5

## Variable Voltage Output Settings

The variable voltage output option has the capability of two different voltage ranges: a 0-5Vdc range as standard, and a user-selectable 0-3Vdc range.

The full list of commands on how to change the voltage output is available from Parker.

The following tables can be used to relate the analog output to an ISO or NAS code.

For example, in a 0-5Vdc range, ISO code 16 is equal to an output of 3.5Vdc. In a 0-3Vdc range, ISO code 8 is equal to an output of 1.0Vdc.

Table relating ISO codes to voltage output

ISO	Err	0	1	2	3	4	5	6	7	8	9	10	11
0-5Vdc	<0.2	0.3	0.5	0.7	0.9	1.1	1.3	1.5	1.7	1.9	2.1	2.3	2.5
0-3Vdc	<0.15	0.2	0.3	0.4	0.5	0.6	0.7	0.8	0.9	1.0	1.1	1.2	1.3

ISO	12	13	14	15	16	17	18	19	20	21	22	Err
0-5Vdc	2.7	2.9	3.1	3.3	3.5	3.7	3.9	4.1	4.3	4.5	4.7	>4.8
0-3Vdc	1.4	1.5	1.6	1.7	1.8	1.9	2.0	2.1	2.2	2.3	2.4	>2.45

Table relating NAS codes to voltage output

ISO	Err	00	0	1	2	3	4	5	6	7	8	9	10	11	12	Err
0-5Vdc	<0.4	0.6	0.9	1.2	1.5	1.8	2.1	2.4	2.7	3.0	3.3	3.6	3.9	4.2	4.5	>4.6
0-3Vdc	<0.2	N.S.	0.3	0.5	0.7	0.9	1.1	1.3	1.5	1.7	1.9	2.1	2.3	2.5	2.7	>2.8

# icountPD<sup>®</sup>

## Display Parameters (ISO 4406/NAS 1638)

### Digital display indication

The digital display will show the actual measured codes, the channel ( $\mu$ ) size and the user definable limits. Visible display of the channel size and user definable limits will alternate.

The order of trigger for both of the codes and moisture sensor option is:

- Solid digit(s) = code(s) that are at or below the set point (limit)

- Flashing digit(s) = code(s) that are above the set point (limit)
- The display for ISO4406 and NAS1638 are identical. The ISO display is shown below.



### LED display indication

The LED display uses 3 sets of LED for the indication of ISO 4406 and NAS1638 code figures. Individual code lights will trigger based on the customer settings. The order of trigger will be:

- Solid green = one ISO code, or better, below the set point (limit)
- Blinking green = ISO code at the set point (limit)
- Solid red = one ISO code above the set point (limit)
- Blinking red = two ISO codes, or more, above the set point (limit)

# icountPDZ

## ATEX Approved Online Particle Detector For Use in Explosive and Hazardous Areas

The icountPD Particle Detector from Parker represents the most up to date technology in solid particle contamination analysis. This compact, permanently mounted laser-based ATEX approved particle detector module is designed for use in Zone II areas and is housed in a robust Stainless Steel IP69K approved enclosure that provides a cost effective solution to fluid management and contamination control.



### Features and Benefits

- Independent monitoring of system contamination trends.
- Assembled in an approved and certified Stainless Steel enclosure to comply with ATEX Directive 94/9/EC.
- Can be used in explosive and hazardous areas.
- ATEX Zone II.
- Certified to CE Ex II 3GD, Ex nA IIC T4 Gc, Ex tc IIIC Dc SIRA 09ATEX4340X and IECEx SIR 09.0137X (-30°C < Ta < +60°C).
- Warning limit relay outputs for low, medium and high contamination levels.
- Continuous performance for prolonged analysis.
- Self diagnostic software.
- Full PC/PLC integration technology such as:- RS232 and 0-5Volt, 4-20mA, CAN(J1939) (Contact Parker for other options.)
- Setup and Data logging support software included.

## icountPD® Auxiliary Flow Device

This simple to use flow control device fits on the downstream (outlet) side of the icountPD and is fitted with a differential pressure valve that adjusts the system flow to a range inside the icountPD specifications.



P/N ACC6NN019

Working pressure range	145 to 4351 psi (10 to 300 bar)
Differential pressure range	145 to 4351 psi (10 to 300 bar)
Working viscosity range	10 to 150 cSt (59 to 696 SUS)

# icountPD<sup>®</sup>/icountPDR/icountPDZ

Optional Accessories				
Description	Part Number	IPD	IPDR	IPDZ
	Aviation/ Diesel Fuel			
1 Meter Hose Length	ACC6NN001	X		
2 Meter Hose Length	ACC6NN003	X		
5 Meter Hose Length	ACC6NN005	X		
1/4" BSP Test point	ACC6NN007	X		
1/8" BSP Test point	ACC6NN009	X		
1/8" NPT Test point	ACC6NN011	X		
Single Point Sampler	SPS2021	X	X	X
US Power Supply	ACC6NE010	X	X	X
European Power Supply	ACC6NN013	X	X	X
5 meter, M12, 8-pin plug and socket cable kit*	ACC6NN014	X		
Deutsch 12-pin connector kit	ACC6NN016	X	X	
RS232 to USB converter	ACC6NN017	X	X	X
12" long M12 8-way RS232 & power cable kit	ACC6NN018	X		X
External Flow Device	ACC6NN019	X	X	X
M12, 12 way cable	ACC6NN024		X	

Standard Default Settings for all icountPDs		Default if Options Fitted	
Comms echo	OFF	Relay hysteresis	ON
Verbose errors	OFF	Relay operation for particle limits	ON
STI Sensors used	OFF	Digital display orientation	0 degrees
Reporting standards	ISO	Digital display brightness level	3-mid
Particle limits	19/18/15	0-5V/0-3V output voltage range	0-5V
Measurement period	60 seconds		
Reporting interval	30 seconds		
Power-on mode	AUTO		
Auto start delay	5 seconds		
Date Format	dd/mm/yy		

\* Cable Kit consists of two 5 meter cables to enable all output options (Communications cable and Relay/Power Supply cable).

# icountPD<sup>®</sup>

## icount Particle Detector

### How to Order

Select the desired symbol (in the correct position) to construct a model code. Example:

BOX 1	BOX 2	BOX 3	BOX 4	BOX 5	BOX 6	BOX 7	BOX 8
IPD	1	2	2	2	2	1	30

BOX 1: Basic Assembly	
Symbol	Description
IPD	Standard Particle Detector
IPDR	Particle Detector - Robust
IPDZ	Particle Detector - Hazardous (Zone 2)

BOX 2: Fluid Type <sup>1,2</sup>	
Symbol	Description
1	Mineral Oil
2	Phosphate Ester (iPD, iPDR only)
3	Aviation Fuel (4channel) (iPD, iPDZ only)

BOX 3: Calibration	
Symbol	Description
2	MTD

BOX 4: Display	
Symbol	Description
1	None (iPD, iPDZ only)
2	LED (iPD only)
3	Digital (iPD only)

BOX 5: Limit Relay	
Symbol	Description
1	No (iPDR only)
2	Yes

BOX 6: Communication <sup>3,4</sup>	
Symbol	Description
2	RS232/4-20mA
3	ES232/0-5V (iPD, iPDR only)
5	RS232/CAN-bus (J1939)

BOX 7: Moisture	
Symbol	Description
1	No
2	Yes

BOX 8: Cable Connector <sup>5,6</sup>	
Symbol	Description
10	Deutsch DT Series (iPD, iPDR only)
30	M12, 8-pin plug connector (iPD, iPDZ only)
40	M12, 12-pin plug connector (iPDR only)

#### Notes:

- When "3" is selected in Box 2, "1" must be selected in Box 7.
- Aviation Fuel option can also be used for diesel fluids.
- For iPD and iPDR units, when "5" is selected in Box 6, "10" must be selected in Box 8.
- When "3" is selected in Box 2, "3" cannot be selected in Box 4.
- Contact Parker for additional communication options (RS485, GPRS, LAN, WiFi, Sat, etc.)
- The required connecting cables are available as a kit. The kit consists of two 5 meter cables (Communications cable and Relay/Power Supply cable) to enable all output options. See Accessory table on page 32 for applicable part number.

# Hydrokit®

## Hydrokit® HFD Series

### Detection of Free Water in Diesel

The HYDROKIT is an effective “Go, No-Go” field test designed to periodically check for free water, which is removed to ppm levels by properly operating filter/ separators, Aquacon, and monitor vessels. Samples are normally taken downstream of the vessel, but they can also be taken at other points in the fuel distribution system. The HYDROKIT is designed to indicate free water in excess of 200 ppm by changing the powder contained in the sample tube to a pink color. Other concentrations can be estimated using the other colors on the card.



The HYDROKIT provides better water determination than ASTM D2709 or D4176. The HYDROKIT is designed for “fail-safe” operation, with false negative readings unlikely. Almost any error in performing the test will indicate the presence of wet fuel. If the sample indicates the presence of excessive water, it is always a good practice to repeat the test on a second sample.

#### Features and Benefits

- Easy to Use – Automatically controls the sample size. Simple evaluation by color comparison.
- Shelf Life – For details on shelf life refer to date on box or contact us at 1-800-531-0180.
- Responds Consistently – Responds consistently in a wide variety of undyed diesel fuels.
- Carefully Controlled Quality – Manufactured by Parker HFFD to strict quality control specifications.

#### Application

- Diesel Fuel, undyed

#### Ordering Information

Part Number	Description
HKD 25	Hydrokit with 25 test tubes

Each model above comes complete with:

- Sample tubes
- Wide mouth glass sample jar(s)
- Needle holder assembly
- Instruction card
- Color indicator comparison card

# Par-Test™

## Fluid Analysis

Complete laboratory analysis.

Fluid analysis has proven to be a critical tool for any preventive maintenance program. Fluid analysis is able to identify potential problems that cannot be detected by human senses. A comprehensive fluid analysis program can help prevent major hydraulic or lube oil system failures.

Par-Test is a complete laboratory analysis, performed on a small volume of fluid. The report you receive is a neatly organized three page format. One may quickly analyze the test results of an individual sample and/or look at a trend analysis for up to five different samples. Two types of services are offered through Par-Test, a water base fluid analysis kit or a petroleum base fluid analysis kit. For both types of services the Par-Test kit includes a pre-cleaned glass bottle, mailing container with pre-addressed label, sample information data sheet (to be completely filled out by end user) and the following analysis:



### Petroleum Base Kit

- Particle count photomicrograph
- Free water analysis
- Spectrometric analysis
- Viscosity analysis
- Water analysis (PPM)
- Neutralization analysis

### Water Base Kit

- Particle count
- Photomicrograph
- Spectrometric analysis
- Viscosity analysis
- Neutralization analysis

Part Numbers	Description
927293	Petroleum base fluid kit (Carton of 10 bottles)
932995	Water based fluid kit (Single test bottle)

Fluid sampling for Par-Test involves important steps to insure you are getting a representative sample. Often, erroneous sample procedures will disguise the true nature of the system fluid. A complete sampling procedure is detailed on the back of this brochure. There also is a National Fluid Power Association standard (NFPA T2.9.1-1972) and an American National Standards Institute Standard (ANSI B93.13-1972) for extracting samples from a fluid power system.

# Par-Test™ Fluid Analysis

For our Par-Test™ customers, the analysis report is available online for your ease and convenience. Historical data is also available. Visit [www.partestlab.com](http://www.partestlab.com)

SAMPLE CODE: 12/9/6	DATE: 03/23/16		PARTEST Fluid Analysis Service Parker Hannifin Corporation 1016 E. Airport Rd. Stillwater, OK 74075 Tele: (405) 624-0400 Fax: (405) 624-0401
Clean Fluids Company 1234 Filtration Ave ISO, OH, 181613 ATTN: Valued Customer			

COMPANY NAME:	Clean Fluids Company	SAMPLE DATE:	3/16/2016
SYSTEM TYPE:		HOURS:	(on oil): (on unit):
EQUIPMENT TYPE:		SYSTEM VOLUME:	
MACHINE ID:	Cat?	FLUID TYPE:	Diesel
FILTER ID:		ANALYSIS PERFORMED:	N2,S,T,V4,W

AUTOMATIC PARTICLE COUNT ISO 11171		
Size	Counts per ml	ISO Code
>4 µm(c)	31041.9	
>6 µm(c)	11388.5	
>10 µm(c)	3375.2	
>14 µm(c)	1473.5	22/21/18
>21 µm(c)	445.0	
>38 µm(c)	32.4	
>50 µm(c)	7.5	
>70 µm(c)	2.7	

FREE WATER PRESENT
NO

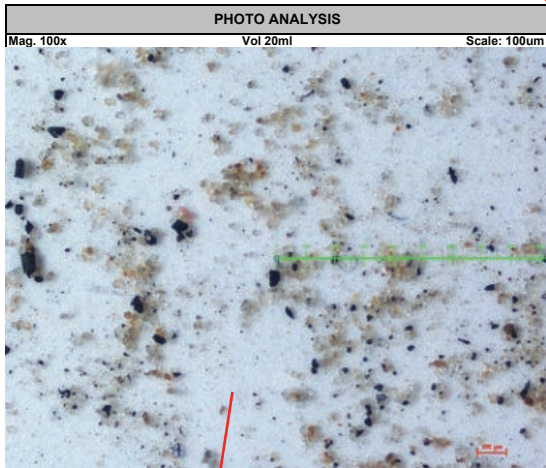
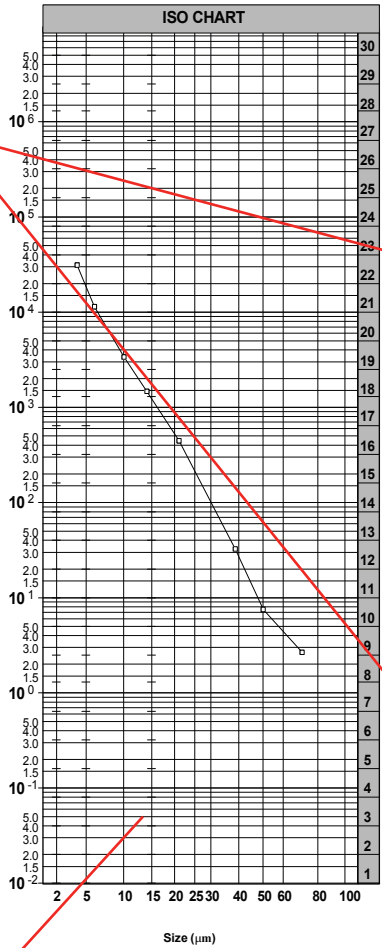

ALARMS/REMARKS	
No recommended ISO target level	
Blank = No alarm provided due to insufficient information	
Report	Green at (All tests Normal) **See below
Number	2=Caution (One or more tests=Caution or 1 Attn Req.)
Alarm	3=Attention Required (Two or more tests=Attn Req)

\*\*If no recommended cleanliness level is provided the Alarm system will not take in account the particle count

### Sample Data

Information supplied by the user regarding the fluid to be analyzed. Complete and accurate information is crucial for a useful analysis.

### Particle Count

Results are reported over 6 different particle size ranges and expressed as an ISO code (modified). The counts are per milliliter of fluid and the reporting is cumulative; i.e. The particle count in the >2 micron row includes the number of particles greater than 5, 10, 15, 25 and 50 microns as well as particles between 2-5 microns in size. Particle resuspension method is utilized for water based fluid samples.

### Free Water Analysis

Determines if the water present is beyond the saturation point of the fluid. At the saturation point, the fluid can no longer dissolve or hold any more water.

### Photo Analysis

A photomicrograph of a small volume of fluid (20 ml) magnified 100X. This analysis gives a quick glance at the contamination present in the fluid. Each line of the graduated scale represents 20 microns in size.

The full color photomicrograph helps identify particles which would otherwise be grouped by class.

### ISO Chart

Graphically illustrates the particle count on a graph. The recommended cleanliness code level, if given on the submittal form, is shown by a broken line on the ISO chart.

# Par-Test™ Fluid Analysis

For our Par-Test™ customers, the analysis report is available online for your ease and convenience. Historical data is also available. Visit [www.partestlab.com](http://www.partestlab.com)



## FLUID ANALYSIS REPORT

Page 2

SAMPLE CODE: 12/9/6	DATE: 03/23/16		<b>PARTEST Fluid Analysis Service</b> Parker Hannifin Corporation 1016 E. Airport Rd. Stillwater, OK 74075 Tele: (405) 624-0400 Fax: (405) 624-0401
Clean Fluids Company 1234 Filtration Ave ISO, OH, 181613			
ATTN: Valued Customer			

SPECTROMETRIC ANALYSIS		
WEAR METALS AND ADDITIVES	PPM BY WEIGHT	*STATUS
IRON	<1.0	
COPPER	4.0	
CHROMIUM	<1.0	
LEAD	<1.0	
ALUMINUM	<1.0	
TIN	<1.0	
SILICON	<1.0	
ZINC	<1.0	
MAGNESIUM	<1.0	
CALCIUM	<1.0	
PHOSPHORUS	3.0	
BARIUM	<1.0	
BORON	<1.0	
SODIUM	<1.0	
MOLYBDENUM	<1.0	
SILVER	<1.0	
NICKEL	<1.0	
TITANIUM	<1.0	
MANGANESE	<1.0	
ANTIMONY	<1.0	

\*VL = VERY LOW L = LOW N = NORMAL H = HIGH VH = VERY HIGH

The Spectrometric Analysis reports the ppm level of 20 different wear metals and additives in the sample. Generally the first 7 and last 5 elements are considered wear elements not normally present in hydraulic oil. Zinc through molybdenum (shaded) represent some common additives in oil. If a baseline oil sample (new oil out of a drum) is provided, then comments on the analyzed sample can be provided on whether the status of the elements are low, normal, or high.

VISCOSITY ANALYSIS - ASTM D445	
CST@100C:	SUS@210F:
CST@40C: 1.71	SUS@100F: 31.6

Viscosity at 40C (100F) is reported in Centistokes (cSt) and SUS (Saybolt Universal Seconds). The test is conducted in accordance with ASTM D445 procedures for determining the kinematic viscosity of fluids.

NEUTRALIZATION ANALYSIS - ASTM D974	
TAN:	0.08

The Total Acid Number (TAN) test measures the acidity of a hydraulic fluid. The higher the number, the more acidic the fluid. Over time this may mean the fluid is becoming oxidized.

WATER ANALYSIS - ASTM D6304	
WATER CONTENT (ppm):	62.1

The water analysis test shows the actual parts per million of water in a sample. This is known as the Karl Fischer titration test and is conducted in accordance with ASTM D6304.

Comments
No baseline oil for Diesel is present in our current baseline oil library. Please forward a new/fresh oil sample for analysis.

**Viscosity Analysis**  
Viscosity is a very important property of a fluid in terms of system performance. Viscosity expresses the internal friction between molecules in the fluid. Typically a breakdown in viscosity will be seen as an increase. Both SSU at 100° F and cSt at 40° C are reported.

**Neutralization Analysis**  
Referred to as the Total Acid Number (TAN) this titration test measures the acid level of the sample fluid. The production of acidic material causes oxidation degradation or aging of most fluids. This activity is promoted by elevated temperatures, presence of entrained metal particles, and intimate contact with air. It is the rate of increase of the TAN during any given time period that is significant, not just the absolute value.

**Water Analysis**  
Karl Fischer test gives accurate measure of water concentration in the sample fluid. The results are reported in parts per million (PPM) and allow for detection of water levels well below the saturation point.

**Remarks**  
Quick statements or alerts about any unusual results from one of the tests reported on this page.

### Spectrometric Analysis

Results obtained by Rotating Disk Electrode (ROE) Spectrometer and reported in terms of parts per million (PPM). Twenty different wear metals and additives are analyzed to help determine the condition of the fluid. The spectrometric test is limited to identifying particles below 5-7 micron in size. Base line (new) fluid samples should be sent in for each different fluid to be analyzed. This will be used to determine the status.

# Low Range DIGI Water Kit

The DIGI Test Cell provides simple, accurate results for water in oil/fuel (including diesel and biodiesel)

With an easy to read digital display providing instructions and results, a five year (10,000 tests) battery life and built in memory for recording previous test results, the DIGI Cell has become a favored test method world-wide for on-site and on-board testing.

## Reagents, Spares and Consumables

Test kits for individual parameters contain reagents, consumables and full instructions for multiple tests.

- Replacement reagents can be ordered at short notice.
- Kits contain all necessary equipment for instant test results in the field.
- Reagents are packed in accordance with IATA/IMDG/IRD Air/Marine/Road Transportation codes and can be delivered to major ports world-wide.

## Water in Oil/Fuel

Maintain and protect your equipment, while eliminating damage caused by water in oil/fuel.

- Prevent corrosion, cavitation or failure of your machinery by detecting water in oil/fuel, before any damage occurs.
- Minimize instability of additive packages and damaging microbe growth by monitoring your oil/fuel.
- Fully portable for use on-board or in the field, test cells are extremely robust, durable and easy to use.



## Specifications

Ranges	200-3000 ppm .02 - 1% 0 - 10%
Test Time	3 Minutes
Battery Life	Five years (10,000 tests)

Electronic display gives step by step test instructions

Latest transducer technology for improved accuracy and ease of cleaning

Simple to use keypad for ease of use

Lightweight glass reinforced plastic body

Nonslip twist grips



## Ordering Information

Part Number	Description
FGK17032PA	Low Range DIGI Water Kit
FGK2101PA	Water in Oil/Fuel Reagent Pack (50)





- off-line and portable
- provide flexibility for removing contaminants from fuel, hydraulic and lubrication fluid
- supports your existing filtration system
- improves and extends the life of your fluid and system components

## Therapeutic

Supports, Improves, Fortifies

---



# Guardian®

## Portable Filtration System



The Guardian portable filtration system is a unique pump/motor/filter combination designed for conditioning and transferring petroleum-based and water emulsion fluids. It protects your system from contamination added with new fluid because new fluid is not necessarily clean fluid. Most new fluids right out of the drum are unfit for use due to high initial concentrations of contaminants. Contamination may be added to a new fluid during processing, mixing, handling, and storage.

The Guardian also circulates and “polishes” fluid in your existing systems to reduce the contamination to an acceptable level. There are hundreds of applications that the Guardian is suited for, with more being discovered each day. If your system is sensitive to the harmful effects of contamination, then the Guardian may be ideal for you.

Features	Advantages	Benefits
Lightweight, hand held, compact design	Easy to carry and fits easily on top of 55 gallon drums.	One person operation, capable of getting to hard to reach areas.
Flow rate to 4 gpm (18 lpm).	Filters and transfers simultaneously.	One step operation.
Pump/motor combination with Carboxylated Nitrile seals standard.	Handles fluids up to 16,000 SUS viscosity (11,000 SUS -24 VDC).	Reliable performance in a wide variety of operating conditions.
Built-in relief valve with no downstream fluid bypass.	Only filtered fluid reaches downstream components.	100% filtration ensured, even when unattended.
Wide variety of filter elements available.	High capacity 2 micron absolute disposable microglass to 74 micron cleanable wire and water removal.	Maximizes element life between changes.
Clear, wire-reinforced 5' hose assemblies with wand attachments.	No additional hardware required.	Ready to use and easy to maneuver.
Optional quick disconnect hose connections.	Fast, easy setup and tear-down.	Eliminates messy drips.
Heavy-duty ¼ HP, 115 VAC (230 VAC, 24 VDC- optional) motor with thermal overload protection.	UL recognized and CSA listed, with replaceable brushes.	Safe, reliable performance; field serviceable.
Geroter pump with visible serviceable inlet strainer.	Dirt tolerant design with added protection.	Pump reliability in highly contaminated fluids.
Quiet operation.	Less than 70dB noise level @ 3 feet.	Can be used most anywhere with minimal disturbance.
Convenient inlet-to-outlet hose connection.	Contains fluids when transporting.	Clean and safe operation.
Low center of gravity.	Guardian stability.	Unattended reliability.
Dual motor seals.	Added motor protection.	Longer motor life.
Auxiliary inlet/outlet ports.	Used in place of, or in addition to, standard ports. The outlet can also be used as a sampling port.	Flexibility.

# Guardian<sup>®</sup>

## Specifications and Installation

### Maximum Allowable Operating Pressure (MAOP)

50 psi (3.4 bar)

### Flow Capacity

Up to 4 gpm (15 lpm)

### Maximum Recommended Fluid Viscosity

(.85 specific gravity)  
110-120 VAC and 220-240 VAC -  
16,000 SUS  
24VDC - 11,000 SUS

### Warning

Explosion hazard. Do not pump flammable liquids such as gasoline, alcohol, solvents, etc.

### Operating Temperatures

Unit -15°F to 180°F (-26°C to 82°C)  
Wand/Hose 25°F to 120°F (-4°C to 49°C)

### Visual Indicator

Differential pressure type, set at 25 psid (1.7 bar)

### Recommended Fluids

Petroleum based oils, water emulsions, and diesel fuels

### Integral Relief Valve

Set at 50 psi (3.4 bar) for motor protection.

### Noise Level

<70db at 3 ft.

### Electrical Motor

¼ hp@2500 rpm.  
24 VDC; 10A max.  
110-120 VAC; 50/60 Hz; 3A max.  
220-240 VAC; 50/60 Hz; 1.5A max.  
Thermal overload protected.  
Replaceable brushes (500 hours).

### Weight

Approximately 24 lbs (10.8 kg)

### Materials

Housing - cast aluminum  
Cover - die cast aluminum  
Handle and Indicator - nylon  
Wands and Hose - PVC  
Fittings - brass  
Seals - fluorocarbon/carboxylated nitrile

### Dimensions

mm  
in

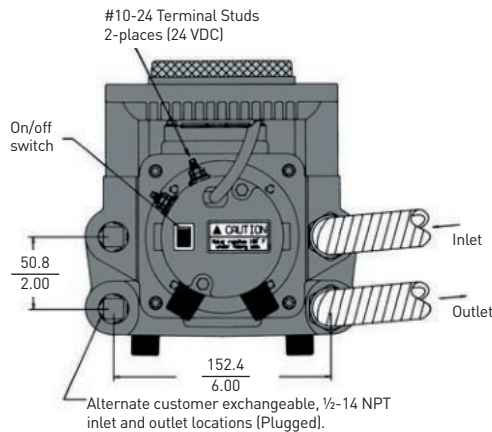
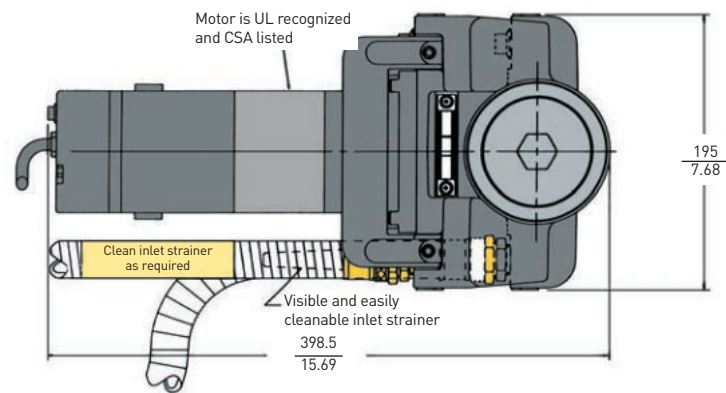
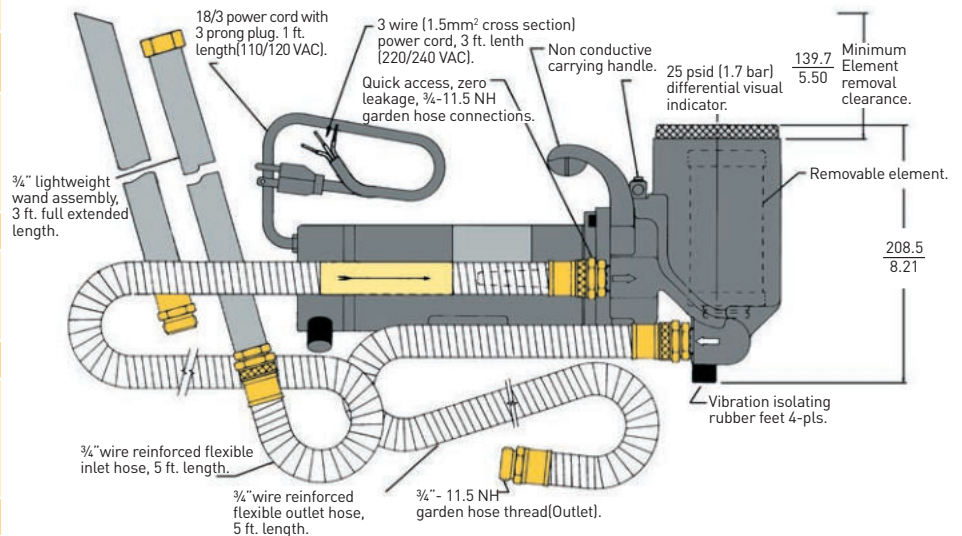

### Guardian Schematic

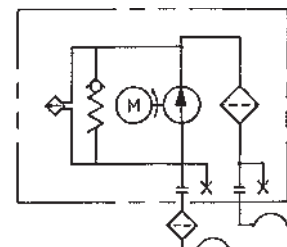

# Guardian®

## Element Performance

Media Code	Filter Media	Time Averaged Beta x/y/z =2/20/75 Where x/y/z is:	Dirt Capacity (Grams)	Beta Rating	Efficiency at x Particle Size
74W	Woven Wire	74 micron <sup>1</sup>	*	B <sub>x</sub> = 2	50.0%
40W	Woven Wire	40 micron <sup>1</sup>	*	B <sub>x</sub> = 20	95.0%
25W	Woven Wire	25 micron <sup>1</sup>	*	B <sub>x</sub> = 75	98.7%
20C	Cellulose	20 micron <sup>1</sup>	*	B <sub>x</sub> = 200	99.5%
10C	Cellulose	5/8/16	4	B <sub>x</sub> = 1000	99.9%
20Q	Microglass III	7.1/13.7/17.3	16.2		
10Q	Microglass III	2.7/7.3/10.3	14.4		
05Q	Microglass III	<2/2.1/4.0	14.9		
02Q	Microglass III	<2/<2/<2	14.3		

Multipass test run at 4 gpm (15 lpm) to 35 psid (2.4 bar)

<sup>1</sup>Reference ratings only. Not multipass tested due to coarseness.

\* Not applicable

### Estimated Guardian Element Life and Cleanliness Levels

The following chart shows typical element life (in gallons of oil passed) and cleanliness levels achieved by standard Parker elements available with the Guardian. Some assumptions have been made.\*

Media Code	New Oil ISO	ISO Achieved	Element Life	Elements Used per 250 gallons
10C	22/20/16	21/19/15	120 gallons	2.08
20Q	22/20/16	21/19/15	486 gallons	.51
10Q	22/20/16	19/16/14	407 gallons	.61
05Q	22/20/16	17/15/12	330 gallons	.75
02Q	22/20/16	15/13/10	316 gallons	.79

\* 1. New oil is at ISO 22/20/16.

2. No environment or work ingestion.

3. Single pass oil transfer.

NOTE: Data for fluid transfer only. For continuous fluid polishing, lower ISO cleanliness levels will be achieved.

### Guardian Flow vs. Viscosity Performance

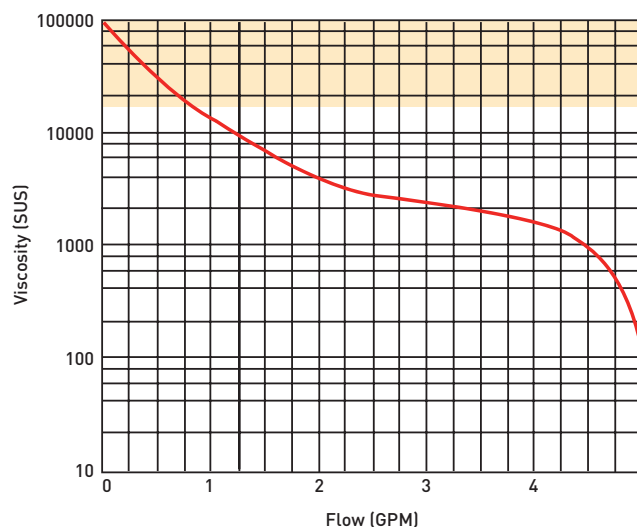

Note 1: Guardian not recommended for fluid viscosities greater than 16,000 SUS (11,000 SUS;24VDC)

Note 2: Flows based on Guardian with no element installed

# Guardian®

## Replacement Parts

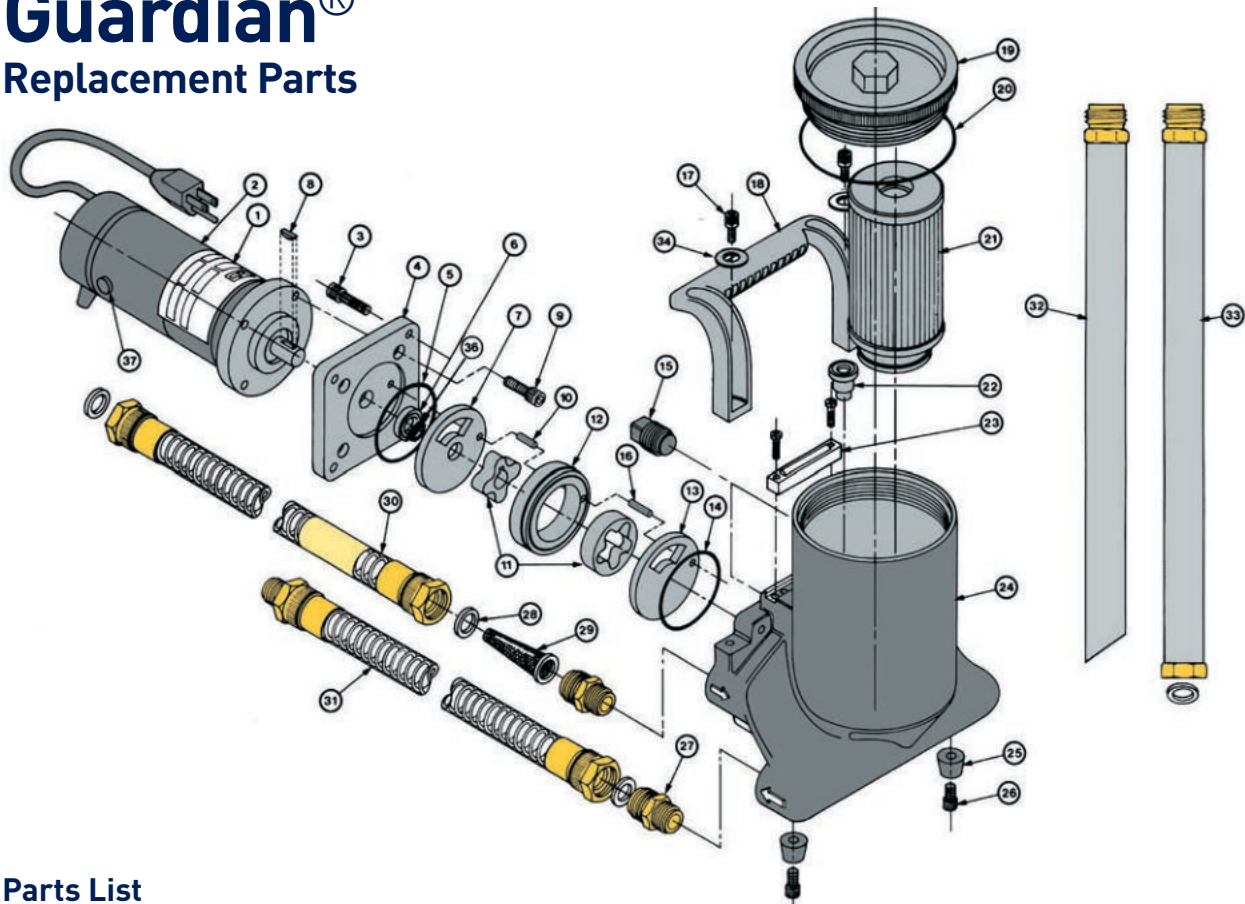

### Parts List

#	Part Number	Description
1	CF	LABEL
2	931913 932381 932759	MOTOR (110-120 VAC) MOTOR (220-440 VAC) MOTOR (24 VDC)
3	902734	SOCKET HEAD CAP SCREW (4), 1/4-20X1
4	931890	ADAPTER PLATE
5	V72041	HOUSING O-RING
6	931921	POLYPAK SEAL
7	931899	SHADOW PLATE
8	931877	WOODRUFF KEY 1/8 X 3/8
9	902679	SOCKET HEAD CAP SCREW (4), 1/4-20 X 3/4
10	903630	ROLL PIN 1/8 X 3/4
11	931873	GEROTER SET
12	931903	GEROTER RING
13	931900	OUTLET PLATE
14	V72135	GEROTER O-RING
15	931920	BRASS PIPE PLUG (2) 1/2-14
16	903426	Roll Pin 1/8 x 5/8
17	931889	SOCKET HEAD CAP SCREW (2), 1/4-20 x 5/8
18	931897	HANDLE
19	931892	COVER
20	V72237	COVER O-RING

#	Part Number	Description
21	SEE 44	ELEMENT
22	928981	RELIEF VALVE
23	927422	INDICATOR KIT
24	931838	HOUSING
25	931888	RUBBER BUMPERS (2)
26	902907	SOCKET HEAD CAP SCREW (2), 1/4-20 x 1/2
27	931928	BRASS FITTING (2)
28	931956	GASKET (4)
29	931927	INLET SCREEN
30	931936	INLET HOSE ASSEMBLY
31	931937	OUTLET HOSE ASSEMBLY
32	931965	WAND CREVICE ASSEMBLY
33	931966	WAND ADAPTER ASSEMBLY
34	926106	WASHER (2)
35	932097	QUICK DISCONNECT KIT (NOT SHOWN)
36	932085	WASHER
37	934329 934327 932761	BRUSH KIT (110/120 VAC) BRUSH KIT (220/240 VAC) BRUSH KIT (24 VDC)
	932263	SEAL KIT
	932081	BOWL EXTENSION KIT

CF - Consult Factory

# Guardian®

## Portable Filtration System

### How to Order

Select the desired symbol (in the correct position) to construct a model code. Example:

BOX 1	BOX 2	BOX 3	BOX 4
	GT4	10C	1

BOX 1: Seals	
Symbol	Description
<b>None</b>	<b>Carboxylated Nitrile</b>

Note: Consult factory for fluids not compatible with fluorocarbon.

BOX 2: Model	
Symbol	Description
<b>GT4</b>	<b>110/120VAC</b>
GT4D	24VDC
GT4E	220/240 VAC

BOX 3: Media	
Symbol	Description
74W	Wire Mesh
40W	Wire Mesh
25W	Wire Mesh
<b>10C</b>	<b>Cellulose</b>
20Q	Microglass
10Q	Microglass
05Q	Microglass
02Q	Microglass
WR	Water Removal

BOX 4: Options	
Symbol	Description
<b>1</b>	<b>None</b>
6	Quick disconnect hose connections

*Please note the bolded options reflect standard options with reduced lead-time.*

### Replacement Elements

Media	Part No.	Box Qty.	Media	Part No.	Box Qty.
02Q	933467Q	2	20C	932020	2
05Q	932018Q	2	25W	922627	1
10Q	932017Q	2	40W	922628	1
20Q	933468Q	2	74W	922626	1
10C	932016	2	WR	932019	2

# DFC

## Portable Diesel Fuel Filtration Cart

Practical and economical maintenance tool.

Parker's comprehensive asset health management approach extends well beyond traditional methods and brings focus to long term fuel system performance and reliability. Pre-filtration and transfer of diesel and biodiesel fuels is critical in maintaining today's fuel injection systems and extending system component life.

Tight tolerances and higher system pressures require significant improvement in fuel cleanliness and quality. The Parker Diesel Fuel Cart delivers on the promise of high efficiency removal of harmful contaminants that impact injector life and compromise engine performance. Like most fuels, diesel requires filtration prior to use and after long periods of storage.

The use of the Parker Diesel Fuel Cart is a practical and economical maintenance tool that contributes to optimum engine performance, regardless of application.



*Designed for Diesel and Biodiesel blended fuels only. Do not use with Gasoline.*

Features	Advantages	Benefits
Wide variety of elements available	Meets cleanliness standards	Extends component life and improves system performance
Heavy duty frame	Rugged and durable	Built to last
Lightweight and portable	Easy to move from place-to-place	One operator
Eleven-foot hose and wand assemblies included	Additional hardware not necessary	Ready to use as received
Parker's E-Z FORM™ MP Series 7219 kink-resistant nitrile hose	Low pressure suction/return hose and vehicle fuel fill connector line	Specifically made for diesel
Visual indicator		Tells you when to change element
FBO-14 fuel filter	Does not require any tools for filter change outs	Polishes fuel
110V/220V AC motor		
Parker H series gear pump	Fixed displacement loaded gear pump which has a high tolerance to system contamination	Long life
Drip tray		Helps keep the work area safe and clean
Convenient inlet-to-outlet hose connection.	Contains fluids when transporting	Clean and safe operation
Low center of gravity.	Guardian stability	Unattended reliability
Dual motor seals.	Added motor protection	Longer motor life
Auxiliary inlet/outlet ports.	Used in place of, or in addition to, standard ports. The outlet can also be used as a sampling port.	Flexibility

# DFC

## Specifications

<b>Maximum Recommended Fluid Viscosity</b>	Diesel – 200 SUS (44 cSt); 0.85 specific gravity
<b>Flow Rate</b>	16 gpm (60.5 lpm)
<b>Visual Indicator</b>	15 psid (1.03 bar) visual differential
<b>Operating Temperature</b>	17.5°F to +150°F (-8.1°C to +66°C)
<b>Electrical Service Required</b>	110/220 volts, 60/50 Hz, single phase, 9.6/4.8 amp
<b>Electrical Motor</b>	¾ hp @ 3450 rpm, TEFC
<b>Recommended Fluids</b>	Diesel fuels
<b>Construction</b>	Cart frame – Steel Filter head – Die Cast Filter bowl – Steel Hoses – Nitrile Wands - PVC
<b>Weight</b>	107 lbs. (48.5 kg)
<b>Dimensions</b>	Height: 40.7 in (1034 mm) Width: 25.5 in (648 mm) Depth: 19.8 in (503 mm)

## Element Performance

New Tier 4 Diesel Engines require finer filtration and better performance

Typical engine fuel contamination levels, established in 1998 by Worldwide Fuel Charter Committee, required cleanliness of 18/16/13 per ISO 4406. Due to technology advances in High Pressure Common Rail injection systems, the new engines manufactured today require cleanliness levels as low as **12/9/6 or better**. Injector pressures are exceeding 30,000 psi (2,068 bar) and smaller nozzle openings are driving the requirements.

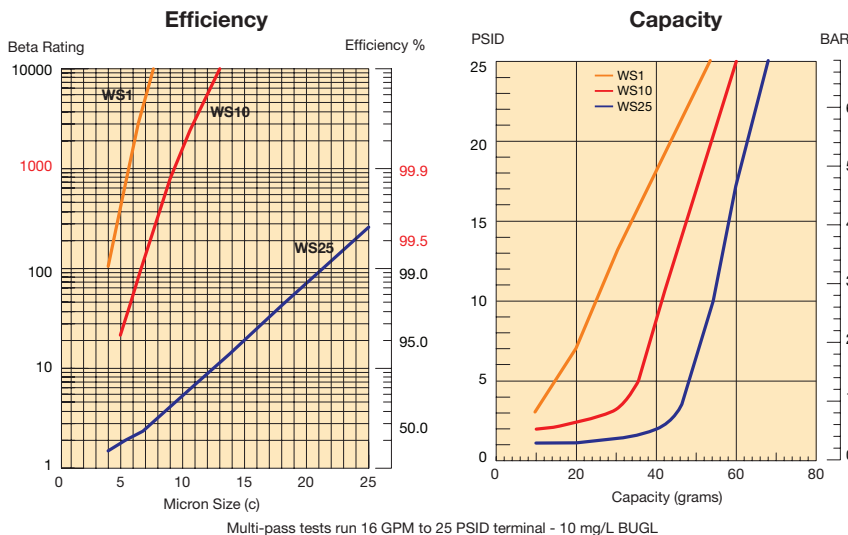

## Element Choices

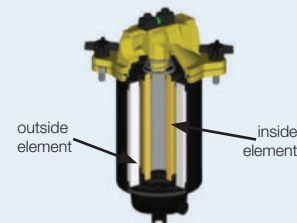

**WS** - Water separator elements are critical when there is a need to remove both particulate and water contamination from fuels. Testing has shown the WS 25 micron element is capable of achieving >99.5% single pass particulate removal efficiency.

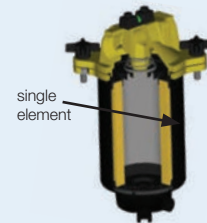

**ST** - Silicone treated elements are ideal for removing particulate contaminants like dust, dirt, rust, sand, scale etc. from fuels. Testing has shown the ST 25 micron elements are capable of achieving >98.8% single pass particulate removal efficiency.

# DFC

## Replacement Parts

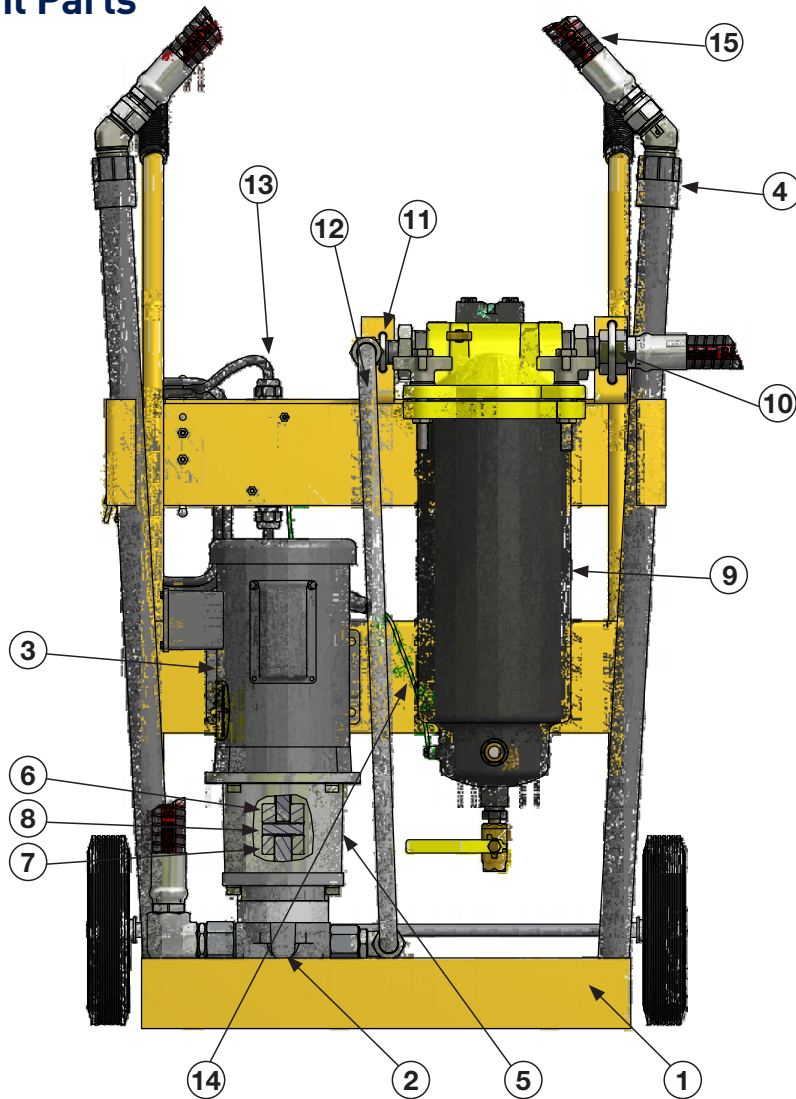

### Parts List

#	Part Number	Description	Qty.	#	Part Number	Description	Qty.
1	945602	DFC cart frame assembly	1	9	945513	Filter housing FBO-14	1
2	943389	H49 gear pump H49AAIAV	1	10	945512	U Bolt SS 5/16-18 thread 2-11/16"	1
3	945579	3/4 HP motor 3600 RPM 60 hz C-face	1	11	945511	U Bolt SS 1/4-20 thread 2" long	1
4	928784	PVC wand - 3 ft	2	12	945508	Tube assembly 3/4 OD 25.11" long	1
5	943042	Pump adapter	1		928616	Heater element (not shown)	1
6	943087	Coupling Lovejoy L075.625	1	13	928617	Manual motor starter (on back)	1
7	943088	Coupling Lovejoy L075.750	1	14	CF	Deutsch connector assembly ground wire	1
8	943133	Spider nitrile L075	1	15	945582B	Hose assembly E-Z Form series 7219 - 8 ft	2

CF - Consult Factory

# DFC

## Portable Diesel Fuel Filtration Cart

### How to Order

Select the desired symbol (in the correct position) to construct a model code. Example:

BOX 1	BOX 2	BOX 3	BOX 4	BOX 5	BOX 6	BOX 7	BOX 8
DFC	14	WS	10	V	V	X	1

BOX 1: Filter Series	
Symbol	Description
DFC	Standard Cart

BOX 2: Model Length	
Symbol	Description
14	Double

BOX 3: Media Code	
Symbol	Description
WS	Water Separator
ST	Silicone Treated Particulate

BOX 4: Degree of Filtration	
Symbol	Description
01	1 micron
10	10 micron
25	25 micron

BOX 5: Seals	
Symbol	Description
V*	Fluorocarbon (FKM)

\* E-Z Form™ MP 7219 Nitrile Hose

BOX 6: Indicator	
Symbol	Description
V	Differential Visual

BOX 7: Bypass	
Symbol	Description
X	No Bypass

BOX 8: Options	
Symbol	Description
1	None

### Replacement Elements

Element	Micron Rating	Coalescer/ Separator	Particulate
FBO-14	1	945515	945519
	10	945517	945521
	25	945518	945522

### Accessories

Part Number	Description
945292	Concentric Wand

### Single Point Suction & Return

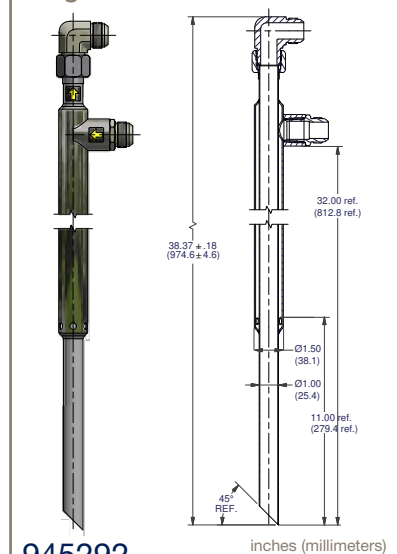

945292

- 1" diameter suction tube
- Fits in openings 1.5 inches and larger
- 32" suction depth
- In-tank filtering
- One port access to the tank
- All steel construction
- Patent pending

# Diesel Filtration Skid

## DFS™ Series

### System for Fuel Condition Monitoring

The Diesel Filtration Skid (DFS) plays an important role in a comprehensive fuel contaminant control program as it provides fuel conditioning to assure the consistent removal of abrasive particles and damaging water.

The DFS offers a complete fuel filtration solution which incorporates both particulate and water contaminant removal technologies mounted on a skid base that can be quickly installed and put into operation.



To learn more about the capabilities of the DFS see page 100.

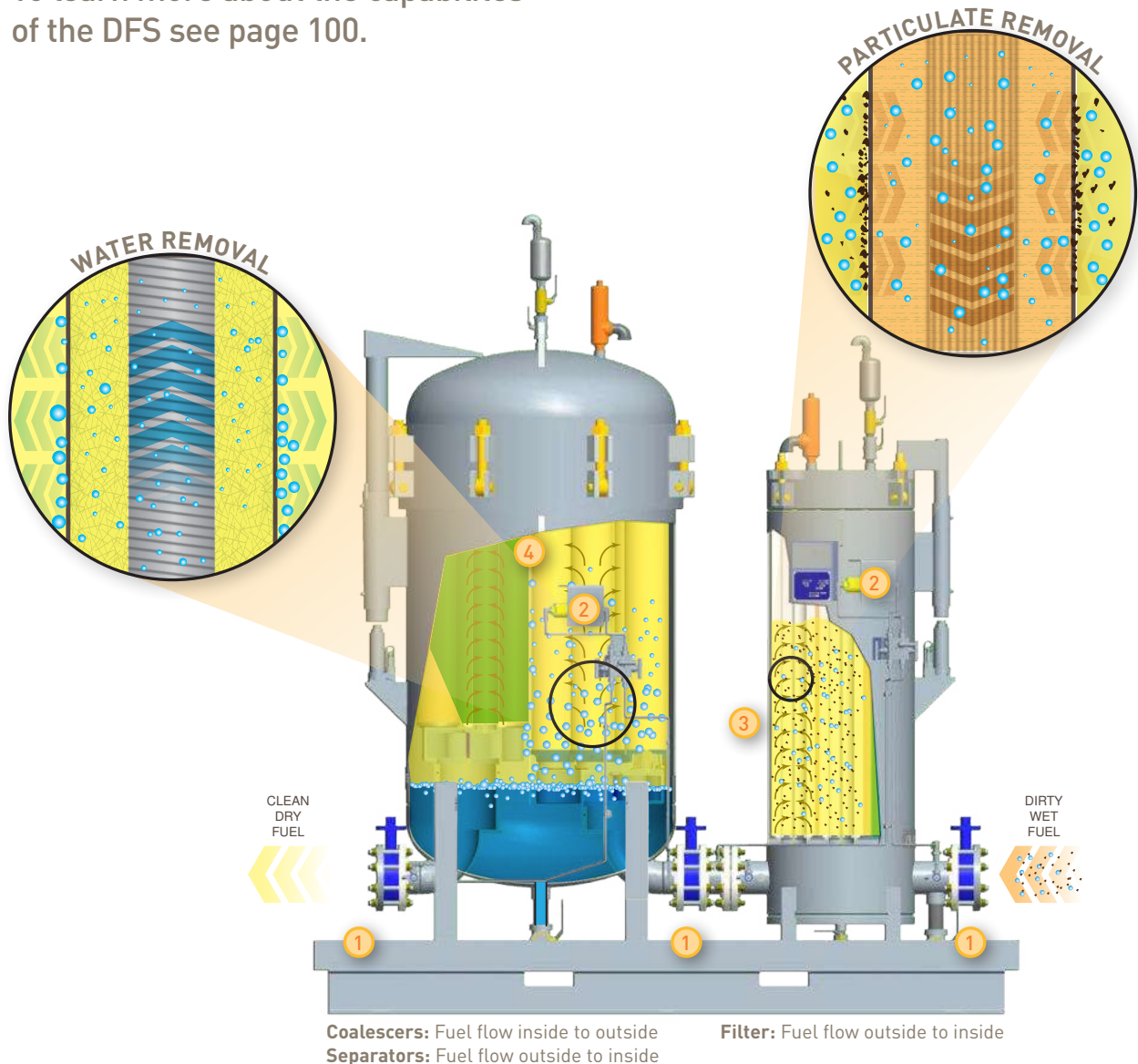



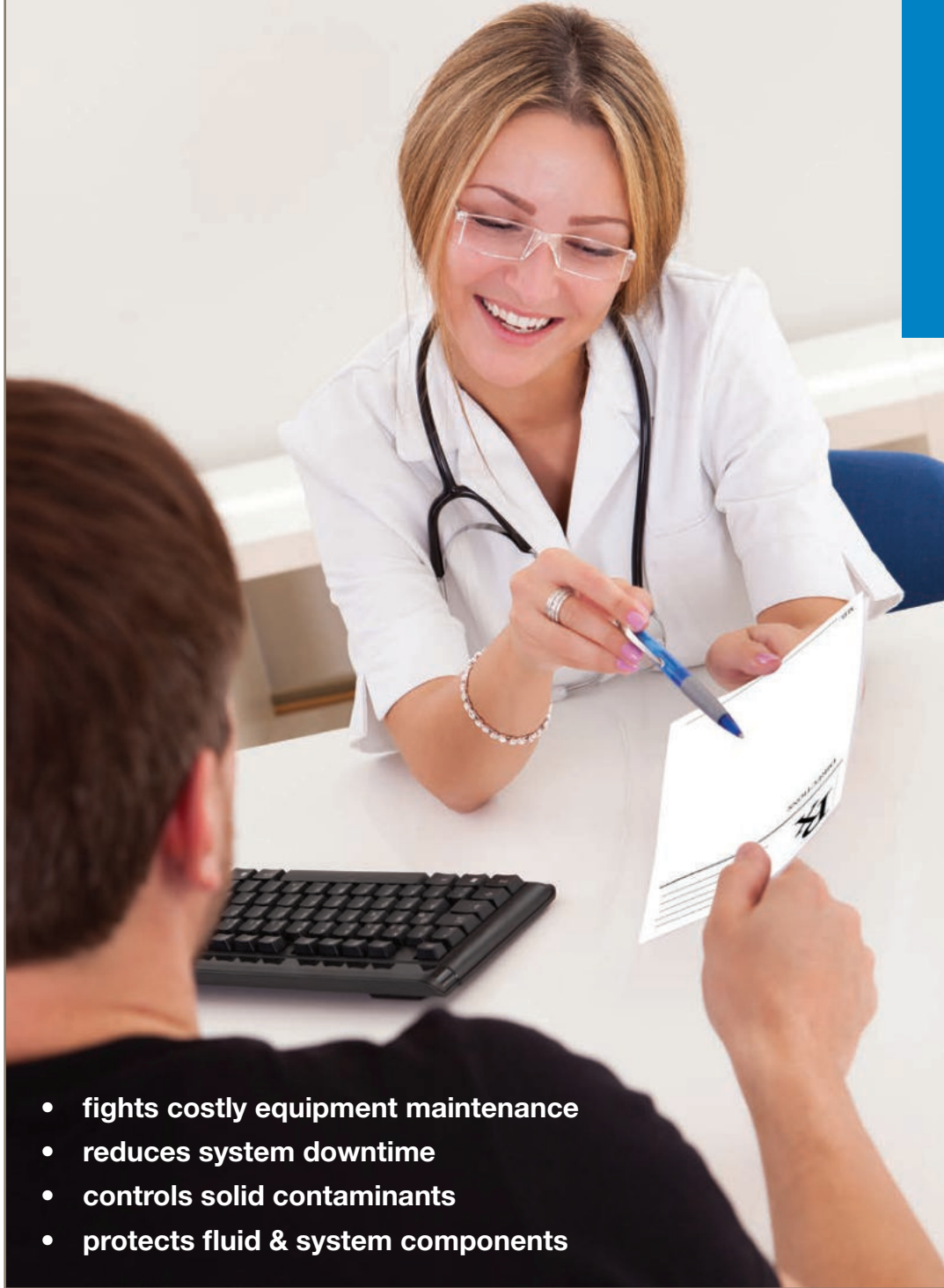
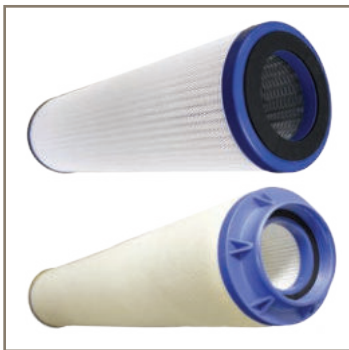

- fights costly equipment maintenance
- reduces system downtime
- controls solid contaminants
- protects fluid & system components

## Preventive

Long Term Defense & Value  
Reduced Cost of Ownership

---

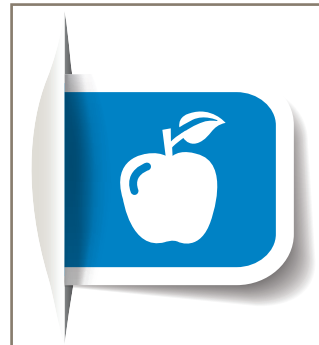

# Diesel Conditioner Plus

## Premium Multifunctional Diesel Conditioner

Degradation, engine heat and oxidation are typical reasons diesel fuel negatively effects your engines performance. The inherent instability of diesel fuels sparked Parker Hannifin into offering a solution for keeping your diesel engine running smoothly.

Designed as an all season multifunctional additive, Parker's Diesel Conditioner Plus provides enhanced power delivery and start-up by stabilizing your diesel fuel. Formulated for regular use in diesel fuel systems, Diesel Conditioner Plus promotes long-term savings by avoiding costly repairs and down-time due to system breakdown.



### Product Features

- Prevents power loss due to fouled injectors
- Works in modern common rail & legacy fuel systems
- Reduces nozzle coking and IDID (Internal Diesel Injector Deposits)
- Cetane improver for added engine performance
- Reduces fuel consumption and emissions
- Lubricity Improver protects against friction and wear
- Corrosion protection
- Biodiesel Compatible

### Applications

- Agriculture
- Construction
- Generators
- Marine
- On Road/Off Road Trucks
- Railroad
- Transportation



# Diesel Conditioner Plus Specifications

Appearance / Color	Dark Amber
Odor	Pungent
Density @ 60°F (15.5°C)	7.93 lb/USG
Flash Point	174.2°F (79°C)
Pour Point	<-59°F (<-50.5°C)
Viscosity @ 68°F (20°C)	6 cSt
Specific Gravity @ 60°F (15.6°C)	0.950

## Directions for use:

For best results, use as directed. Add 1 ounce of Diesel Conditioner Plus per 20 gallons of fuel to maintain fuel systems and prevent deposits. Always add Diesel Conditioner Plus to the fuel tank before adding new fuel. Adding prior to fueling allows for the most effective mixing.

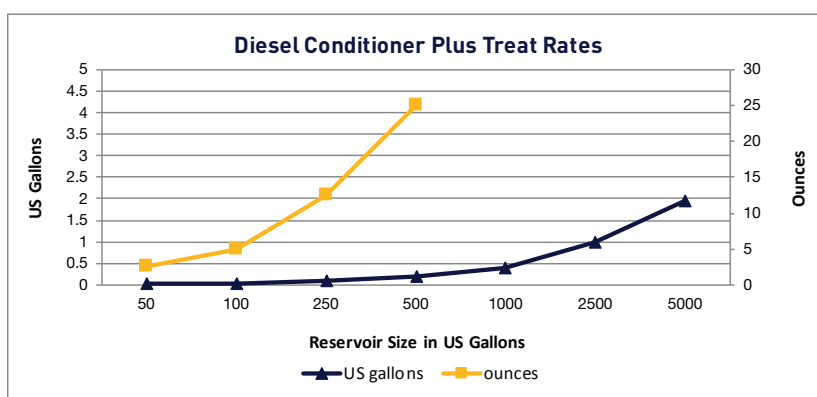

Reservoir Size in US Gallons	50	100	250	500	1000	2500	5000
ounces	2.5	5	12.5	25	50	125	250
US gallons	0.02	0.04	0.10	0.20	0.39	0.98	1.95

## How to Order

Part Number	Description
ADT01116	16 oz (0.47 L)
ADT01201	1 US gal (3.79 L)
CF	5 US gal (18.92 L)
CF	55 US gal (208.19 L)

CF = Consult Factory



**WARNING - COMBUSTIBLE LIQUID. HARMFUL IF SWALLOWED OR INHALED. HARMFUL IN CONTACT WITH SKIN. CAUSES MILD SKIN IRRITATION. TOXIC TO AQUATIC LIFE. TOXIC TO AQUATIC LIFE WITH LONG LASTING EFFECTS. RISK OF EXPLOSION IF HEATED UNDER CONFINEMENT. Avoid breathing dust / fume / gas / mist / vapors / spray. Use only outdoors or in a well-ventilated area. Wear protective gloves / eye protection / face protection. Wash thoroughly after handling. Avoid release to the environment. If skin irritation occurs: Get medical attention. All disposal practices must be in accordance with local, national and international regulations. Collect spillage.**

**FIRST AID:** Eye contact: Immediately flush eyes with plenty of water, occasionally lifting the upper and lower eyelids. Check for and remove any contact lenses. Continue to rinse for at least 10 minutes. Get medical attention if irritation occurs. Skin Contact: Wash with plenty of soap and water. Remove contaminated clothing and shoes. Wash contaminated clothing thoroughly with water before removing it, or wear gloves. Continue to rinse for at least 10 minutes. Get medical attention if adverse health effects persist or are severe. If necessary, call a poison center or physician. Wash clothing before reuse. Clean shoes thoroughly before reuse. Inhalation: Remove victim to fresh air and keep at rest in a position comfortable for breathing. If breathing is labored, administer oxygen. If breathing has stopped, apply artificial respiration. Call a poison center or physician. Ingestion: Wash out mouth with water. Remove dentures if any. Remove victim to fresh air and keep at rest in a position comfortable for breathing. If material has been swallowed and the exposed person is conscious, give small quantities of water to drink. Stop if the exposed person feels sick as vomiting may be dangerous. Do not induce vomiting unless directed to do so by medical personnel. If vomiting occurs, the head should be kept low so that vomit does not enter the lungs. Get medical attention. If necessary, call a poison center or physician. Never give anything by mouth to an unconscious person. If unconscious, place in recovery position and get medical attention immediately. Maintain an open airway. Loosen tight clothing such as a collar, tie, belt or waistband.

Parker Hannifin Corporation Emergency Response Company INFOTRAC 24-Hour Number: US and Canada 1-800-535-5053; International + 1-352-323-3500

# Diesel Winter Conditioner Plus

## Premium Diesel Fuel Winterizer

As the temperature begins to fall, wax crystals can start to form in Diesel Fuel. Parker Hannifin's Diesel Winter Conditioner Plus will reduce the likelihood of diesel fuel "gelling," preventing production freeze ups that can occur in cold temperatures. Keep your engines running at peak performance in all weather conditions.

Diesel Winter Conditioner Plus is added to petroleum distillates such as No. 2 heating oil or diesel fuel to improve low temperature operation and fuel reliability. Diesel Winter Conditioner Plus works around the clock to prevent the plugging of lines, filter screens, valves and critical fuel system components.



### Product Features

- Cold Flow Improver to prevent fuel from gelling
- Deicer to reduce risk of fuel line freeze-up
- Works in modern common rail & legacy fuel systems
- Reduces nozzle coking and IDID (Internal Diesel Injector Deposits)
- Cetane Booster for easier start-ups
- Reduces fuel consumption and emissions
- Lubricity Improver protects against friction and wear
- Corrosion protection
- Biodiesel Compatible

### Applications

- Agriculture
- Construction
- Generators
- Marine
- On Road/Off Road Trucks
- Railroad
- Transportation



# Diesel Winter Conditioner Plus

## Specifications

Appearance / Color	Light Straw, Viscous Liquid
Odor	Hydrocarbon
Density @ 60°F (15.5°C)	7.71 lb/USG
Flash Point	147°F (64°C)
Pour Point	27°F (-3°C)
Viscosity @ 68°F (20°C)	121 cSt
Viscosity @ 107°F (40°C)	43 cSt
Coefficient of Thermal Expansion	0.00087

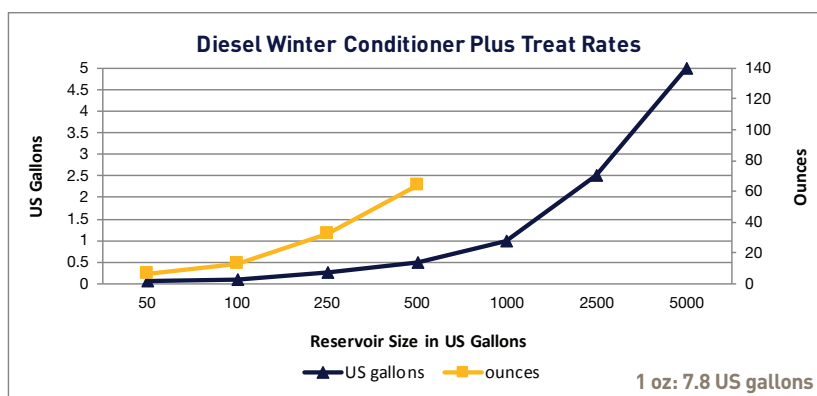

Reservoir Size in US Gallons	50	100	250	500	1000	2500	5000
ounces	6.4	12.8	32	64	128	320	640
US gallons	0.05	0.1	0.25	0.5	1	2.5	5



WARNING - COMBUSTIBLE LIQUID. HARMFUL IF SWALLOWED OR INHALED. HARMFUL IN CONTACT WITH SKIN. CAUSES MILD SKIN IRRITATION. TOXIC TO AQUATIC LIFE WITH LONG LASTING EFFECTS. RISK OF EXPLOSION IF HEATED UNDER CONFINEMENT. Wear protective gloves. Wear eye or face protection. Wear protective clothing. Keep away from flames and hot surfaces. - No smoking. Use only outdoors or in a well ventilated area. Avoid breathing vapor. Do not eat, drink or smoke when using this product. Wash hands thoroughly after handling. Dispose of contents and container in accordance with all local, regional, national and international regulations.

FIRST AID: Eye contact: Immediately flush eyes with plenty of water, occasionally lifting the upper and lower eyelids. Check for and remove any contact lenses. Continue to rinse for at least 10 minutes. Get medical attention if irritation occurs. Skin Contact: Wash with plenty of soap and water. Remove contaminated clothing and shoes. Wash contaminated clothing thoroughly with water before removing it, or wear gloves. Continue to rinse for at least 10 minutes. Get medical attention if adverse health effects persist or are severe. If necessary, call a poison center or physician. Wash clothing before reuse. Clean shoes thoroughly before reuse. Inhalation: Remove victim to fresh air and keep at rest in a position comfortable for breathing. If breathing is labored, administer oxygen. If breathing has stopped, apply artificial respiration. Call a poison center or physician. Ingestion: Wash out mouth with water. Remove dentures if any. Remove victim to fresh air and keep at rest in a position comfortable for breathing. If material has been swallowed and the exposed person is conscious, give small quantities of water to drink. Stop if the exposed person feels sick as vomiting may be dangerous. Do not induce vomiting unless directed to do so by medical personnel. If vomiting occurs, the head should be kept low so that vomit does not enter the lungs. Get medical attention. If necessary, call a poison center or physician. Never give anything by mouth to an unconscious person. If unconscious, place in recovery position and get medical attention immediately. Maintain an open airway. Loosen tight clothing such as a collar, tie, belt or waistband.

Parker Hannifin Corporation Emergency Response Company INFOTRAC 24-Hour Number: US and Canada 1-800-535-5053; International + 1-352-323-3500

### Directions for use:

For best results, use as directed. Add 1 ounce of Diesel Winter Conditioner Plus per 7.8 gallons of fuel to protect most fuels down to -10°F / -23°C. (See chart for additional treat rates.) To protect in a severe climate, double this treat rate when temperatures are expected to drop below -10°F / -23°C (add 2 ounces of Diesel Winter Conditioner Plus per 15.6 gallons of fuel). For optimum performance, add Diesel Conditioner Winter Plus to #2 diesel fuel before the fuel temperature drops below +25°F / -4°C. Diesel Conditioner Winter Plus contains anti-gel chemistry and should be stored at or above +20°F / -7°C to prevent thickening. Always add Diesel Conditioner Winter Plus to the fuel tank before adding new fuel. Adding prior to fueling allows for the most effective mixing.

### How to Order

Part Number	Description
ADT04116	16 oz (0.47 L)
ADT04201	1 US gal (3.79 L)
CF	5 US gal (18.92 L)
CF	55 US gal (208.19 L)

CF = Consult Factory

# DFO Series

## Particulate Filtration

### High Quality Filtration for Diesel and Biodiesel Applications

Diesel fuel is stored and transferred multiple times from refining to dispensing. Preventive action does not always eliminate contamination. Common contaminants introduced during transportation include both extremely fine and abrasive silica as well as pipe scale. These contaminants can quickly deteriorate fuel quality below engine manufacturer standards, reducing the durability and performance of the engine.

Parker DFO filters transform contaminated fuels to meet stringent downstream ISO 4406 cleanliness standards for the demanding limits placed on diesel and biodiesel fuels. The DFO design balances high surface area and depth filtration to maximize filter life which reduces filtration costs.



### Tiered Ratings

To meet industry fuel quality standards, Parker HFFD developed pleated media filters for diesel and biodiesel fuels. In accordance with ISO standards, the DFO filters were designed with tiered media classification using absolute rated media. Each media tier provides a unique solution from managing fuel contamination to final fuel conditioning.

- DFO filters with ratings of 2 and 5 micron are the ultimate solution to condition fuel for dispensing while assuring ISO 4406 Cleanliness Standards are consistently met. Each progressively tighter DFO filter rating delivers additional particle removal and fuel cleanliness; therefore progressively lower ISO 4406 particle counts.

- The mid-range DFO filters of 10 micron extend filter life following secondary conditioning by removing particulate contaminants and allowing Parker's downstream coalescing products to focus on water removal rather than particle removal.
- The DFO filters rated at 25 micron are the ideal solution to manage contaminated fuel entering and leaving terminal storage tanks throughout the fuel transferring process.

### Benefits

- Reduced operating costs by removing particulates that can cause engine damage
- Reliable fuel injector performance when particulate contaminants are removed to meet ISO 4406 Cleanliness Standards
- Improved equipment uptime, reduces equipment failures, repairs, and/or replacements

# DFO Series

## Specifications

- Multi-layer pleated filtration layers using engineered fiber blends for optimum filter life and efficiency.
- All filter components compatible with diesel and biodiesel blends
- Inside diameter
  - 3.5 in (88.9 mm)
- Outside diameter
  - 6 in (152.4 mm)
- Recommended change out pressure: 25 psid (1.7 bar)
- Nitrile sealing materials are standard
- Maximum Operating Temperature: 225°F (107°C)
- End cap configuration options
  - Double open end
  - Threaded base (TB)
- Collapse pressure
  - 75 psi (5.2 bar)
- pH range (continuous operation)
  - 5-9

## Element Part Numbers

Part Number	Length (inch)	Micron Rating (µm)	End Cap Configuration
DFO-512PLF2	12	2	Double Open End
DFO-512PLF5	12	5	Double Open End
DFO-512PLF10	12	10	Double Open End
DFO-512PLF25	12	25	Double Open End
DFO-524PLF2	24	2	Double Open End
DFO-524PLF5	24	5	Double Open End
DFO-524PLF10	24	10	Double Open End
DFO-524PLF25	24	25	Double Open End
DFO-614PLF2	14	2	Double Open End
DFO-614PLF5	14	5	Double Open End
DFO-614PLF10	14	10	Double Open End
DFO-614PLF25	14	25	Double Open End
DFO-629PLF2	29	2	Double Open End
DFO-629PLF2TB	29	2	Threaded Base
DFO-629PLF5	29	5	Double Open End
DFO-629PLF5TB	29	5	Threaded Base

Part Number	Length (inch)	Micron Rating (µm)	End Cap Configuration
DFO-629PLF10	29	10	Double Open End
DFO-629PLF10TB	29	10	Threaded Base
DFO-629PLF25	29	25	Double Open End
DFO-629PLF25TB	29	25	Threaded Base
DFO-644PLF2	44	2	Double Open End
DFO-644PLF2TB	44	2	Threaded Base
DFO-644PLF5	44	5	Double Open End
DFO-644PLF5TB	44	5	Threaded Base
DFO-644PLF10	44	10	Double Open End
DFO-644PLF10TB	44	10	Threaded Base
DFO-644PLF25	44	25	Double Open End
DFO-644PLF25TB	44	25	Threaded Base
DFO-656PLF2TB	56	2	Threaded Base
DFO-656PLF5TB	56	5	Threaded Base
DFO-656PLF10TB	56	10	Threaded Base
DFO-656PLF25TB	56	25	Threaded Base

# Aquacon<sup>®</sup> - AD Series

## Particulate Filtration & Water Removal

### Diesel and Biodiesel (FAME) Protection from Particulate and Water Contaminants

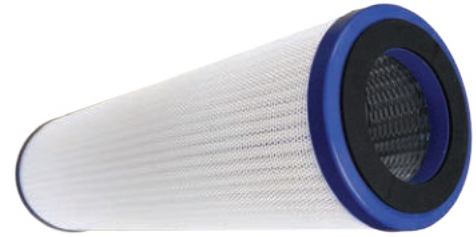

Even when the utmost care is taken, contaminants will be introduced as fuel is transported from the refinery to its point-of-use. Common contaminants, including pipe scale, silica, metal debris and water, can quickly deteriorate fuel cleanliness far beyond engine manufacturer's minimum requirements for fuel cleanliness.

Parker's Aquacon Diesel (AD) filters can remove both particulate and water contaminants in fuels to meet stringent downstream ISO 4406 and ASTM D975 cleanliness standards for both diesel or biodiesel fuels. The AD design incorporates multiple layers of both high efficiency long-life particulate retention and water absorbing media.

### Water Absorbance Versus Water Coalescing

AD filters are designed to remove both water and particulates from either diesel or biodiesel fuels. AD filters are ideal for use in biodiesel and blended fuels where high levels of surfactants (glycerin) could disrupt water coalescing. When continual removal of water from petroleum based fuel is required, the application of coalescing technology is optimal or preferred.

### Tiered Ratings

- Parker's 2 or 5 micron rated AD filters are excellent solutions for delivering fuel ready for dispensing while assuring both ISO 4406 and ASTM D975 cleanliness levels are consistently met. Each progressively tighter AD filter rating adds additional particle removal capability and lowers ISO 4406 particle counts
- The 10 and 25 micron rated filters are ideal for managing fuel contamination entering and leaving terminal storage tanks throughout the fuel transfer process

### Benefits

- More reliable fuel injector performance by reducing particulate which can cause cascading damages
- Reduced operating costs due to repair of equipment damaged by particulate and water contaminants
- Reduced engine maintenance due to fewer components being damaged by contaminants
- More efficient fuel consumption due to fewer inhibiting particulate and water contaminants
- Removes free aqueous contaminants from fuel
- Aquacon - AD series elements are recommended for Biodiesel blends over 5% (B5)

# Aquacon<sup>®</sup> - AD Series

## Specifications

- All filter components compatible with diesel and biodiesel blends
- Recommended change out pressure: 25 psid (1.7 bar)
- Water absorbance and particulate retention will increase differential pressure to the change out pressure
- Nitrile sealing materials are standard
- All AD products will remove free and emulsified water from both diesel and biodiesel fuels to levels below 50 ppm
- The water absorbing technology used in AD filters is not effective in the presence of fuels containing high concentrations of alcohol
- Nitrile sealing materials are standard
- Maximum Operating Temperature: 150°F (65°C)
- End cap configuration options
  - Double open end
  - Threaded base
- Maximum burst pressure
  - 75 psi (5.2 bar)
- pH range (continuous operation)
  - 5-9

## Element Part Numbers

Part Number	Inside Diam (inch)	Outside Diam (inch)	Length (inch)	Micron Rating (µm)	End Cap Configuration
AD-5122	3	5.625	12.25	2	Open End
AD-5125	3	5.625	12.25	5	Open End
AD-51210	3	5.625	12.25	10	Open End
AD-51225	3	5.625	12.25	25	Open End
AD-5242	3	5.625	24.5	2	Open End
AD-5245	3	5.625	24.5	5	Open End
AD-52410	3	5.625	24.5	10	Open End
AD-52425	3	5.625	24.5	25	Open End
AD-6142	3.5	6	14.5	2	Open End
AD-6145	3.5	6	14.5	5	Open End
AD-61410	3.5	6	14.5	10	Open End
AD-61425	3.5	6	14.5	25	Open End
AD-6292	3.5	6	29	2	Open End
AD-6292TB	3.5	6	29	2	Threaded Base
AD-6295	3.5	6	29	5	Open End
AD-6295TB	3.5	6	29	5	Threaded Base

Part Number	Inside Diam (inch)	Outside Diam (inch)	Length (inch)	Micron Rating (µm)	End Cap Configuration
AD-62910	3.5	6	29	10	Open End
AD-62910TB	3.5	6	29	10	Threaded Base
AD-62925	3.5	6	29	25	Open End
AD-62925TB	3.5	6	29	25	Threaded Base
AD-6442	3.5	6	44	2	Open End
AD-6442TB	3.5	6	44	2	Threaded Base
AD-6445	3.5	6	44	5	Open End
AD-6445TB	3.5	6	44	5	Threaded Base
AD-64410	3.5	6	44	10	Open End
AD-64410TB	3.5	6	44	10	Threaded Base
AD-64425	3.5	6	44	25	Open End
AD-64425TB	3.5	6	44	25	Threaded Base
AD-6562TB	3.5	6	56	2	Threaded Base
AD-6565TB	3.5	6	56	5	Threaded Base
AD-65610TB	3.5	6	56	10	Threaded Base
AD-65625TB	3.5	6	56	25	Threaded Base

# DI/DO & DSO Series

## Particulate Filtration

### Particulate and Water Removal from Diesel Fuel

As fuel is transported from the refinery to its point-of-use, it can quickly become contaminated from silica, pipe scale, and water condensate. These contaminants rapidly deteriorate fuel cleanliness far below engine manufacturers minimum for fuel cleanliness.



Parker's DI coalescers in combination with DSO separators, contaminated fuels are cleaned to a level that meets stringent downstream fuel cleanliness standards for petroleum based diesel fuels.

The first stage in the DI coalescer removes particles through an inside-out flow and coalesces emulsified water into large droplets, which then fall to the housing sump. In the second stage, an outside-in process, the DSO separator creates a hydrophobic barrier to block the coalesced water droplets from flowing downstream of the housing. This multi-stage design assures the fuel is conditioned to a clean and dry state, ready for use.

### Surfactants

- Water coalescing is not effective in the presence of fuels containing high levels of surfactants/alcohols or unrefined biofuels
- Detergents and additives inhibits the ability of coalescers to effectively remove water by reducing Interfacial Tension (IFT) and can eventually disarm coalescers
- Contact Parker Laboratories for further analysis of your fuel for presence of surfactants
- Coalescing not recommended for Biodiesel blends over 5% (B5)

### Tiered Ratings

- Parker's 5 micron coalescer combines leading-edge particle removal with world-class coalescing technology to provide optimal fuel cleanliness
- The 10 and 25 micron rated filter coalescer provides effective particle removal with industry proven coalescing technology.

### Benefits

- Extended equipment uptime
- Reduced operating costs
- Reliable fuel injector performance
- Improved equipment uptime
- Reduced fuel system maintenance

# DI/DO & DSO Series

## Specifications

- Multi-layer pleated filtration layers using engineered fiber blends for solids retention. Sequenced coalescing materials to grow large water droplets from emulsified water.
- All filter components compatible with diesel and biodiesel blends
- Inside diameter
  - 3.5 in (88.9 mm)
- Outside diameter
  - 6 in (152.4 mm)
- DI - coalescer flow direction - inside to outside
- DO - coalescer flow direction - outside to inside (DVX Series)
- DSO - separator flow direction - outside to inside
- Recommended change out pressure: 25 psid (1.7 bar)
- Downstream free-water level typically below 50 ppm
- Nitrile sealing materials are standard
- Maximum Operating Temperature: 150°F (65°C)
- End cap configuration options
  - Double open end
  - Threaded base
- Maximum burst pressure
  - 75 psi (5.2 bar)
- pH range (continuous operation)
  - 5-9

## Element Part Numbers

Part Number	Length (inch)	Micron Rating (µm)	End Cap Configuration
DI-622D5TB	22	5	Threaded Base
DI-622D10TB	22	10	Threaded Base
DI-622D25TB	22	25	Threaded Base
DI-633D5TB	33	5	Threaded Base
DI-633D10TB	33	10	Threaded Base
DI-633D25TB	33	25	Threaded Base
DI-638D5TB	38	5	Threaded Base
DI-638D10TB	38	10	Threaded Base
DI-638D25TB	38	25	Threaded Base
DI-644D5TB	44	5	Threaded Base
DI-644D10TB	44	10	Threaded Base
DI-644D25TB	44	25	Threaded Base
DI-656D5TB	56	5	Threaded Base
DI-656D10TB	56	10	Threaded Base
DI-656D25TB	56	25	Threaded Base
DO-815D5	15	5	Open End
DO-815D10	15	10	Open End
DO-815D25	15	25	Open End
DO-830D5	30	5	Open End
DO-830D10	30	10	Open End
DO-830D25	30	25	Open End
DO-844D5	44	5	Open End
DO-844D10	44	10	Open End
DO-844D25	44	25	Open End

Part Number	Length (inch)	Media	End Cap Configuration
DSO-415PL	15	Cellulose	Open End
DSO-430PL	30	Cellulose	Open End
DSO-444PL	44	Cellulose	Open End
DSO-622C	22	Screen	Open End
DSO-622PLF3	22	Cellulose	Open End
DSO-629C	29	Screen	Open End
DSO-629PLF3	29	Cellulose	Open End
DSO-633C	33	Screen	Open End
DSO-633PLF3	33	Cellulose	Open End
DSO-644C	44	Screen	Open End
DSO-644PLF3	44	Cellulose	Open End

# Par<>Fit DFI Series

## Particulate Filtration

### High Flow Particulate Filter for Diesel Fuel

Parker's DFI filters are high quality affordable replacements for Pall® Ultipleat® HFU filter applications. Diesel fuel is stored and transferred multiple times from refining to dispensing. Common contaminants introduced during transportation include both extremely fine and abrasive silica as well as pipe scale. These contaminants can quickly deteriorate fuel quality below engine manufacturer standards, reducing the durability and performance of the engine. Parker has over 60 years of experience in high flow fuel filtration. This experience shows in the design and performance of the DFI series. Parker's DFI filters transform contaminated fuels to meet stringent downstream ISO 4406 cleanliness standards for the demanding limits placed on diesel. The DFI design includes special pleat geometry for high surface area and depth filtration media to maximize filter life and reduce filtration cost.



### Tiered Ratings

To meet industry fuel quality standards, Parker developed pleated media filters for diesel and biodiesel fuels. In accordance with ISO standards, the DFI filters were designed with tiered media classification. Each media tier provides a unique solution from managing fuel contamination to final fuel conditioning.

- DFI filters with ratings of 2 and 4 micron are the ultimate solution to condition fuel for dispensing while assuring ISO 4406 Cleanliness Standards are consistently met. Each progressively tighter DFO filter rating delivers additional particle removal and fuel cleanliness; therefore progressively lower ISO 4406 particle counts.

- The mid-range DFI filters of 6 and 10 micron extend filter life following secondary conditioning by removing particulate contaminants and allowing Parker's downstream coalescing products to focus on water removal rather than particle removal.
- The DFI filters rated at 20 and 40 micron are the ideal solution as pre-filtration for 2-10 micron or to manage contaminated fuel entering and leaving terminal storage tanks throughout the fuel transferring process.

### Benefits

- Reduced operating costs by removing particulates that can cause engine damage
- Reliable fuel injector performance when particulate contaminants are removed to meet ISO 4406 Cleanliness Standards
- Improved equipment uptime, reduces equipment failures, repairs, and/or replacements

# DFI Series

## Specifications

- All filter components compatible with diesel and biodiesel blends
- Outside diameter
  - 6 in (152.4 mm)
- Maximum allowable differential pressure at 50 psid (3.4 bar)
- Recommended change out pressure: 25 psid (1.7 bar)
- Nitrile sealing materials are standard
- Maximum Operating Temperature: 225°F (107°C)
- End cap configuration
  - High Flow
- Maximum burst pressure
  - 75 psi (5.2 bar)
- pH range (continuous operation)
  - 5-9

## Element Part Numbers

Part Number	Outside Diam (inch)	Length (inch)	Micron Rating (µm)
DFI-640PLF2HF	6	40	2
DFI-640PLF4HF	6	40	4
DFI-640PLF6HF	6	40	6
DFI-640PLF10HF	6	40	10
DFI-640PLF25HF	6	40	25
DFI-660PLF2HF	6	60	2
DFI-660PLF4HF	6	60	4
DFI-660PLF6HF	6	60	6
DFI-660PLF10HF	6	60	10
DFI-660PLF25HF	6	60	25

# DFI Series

## Element Performance

### DFI-640... Efficiency

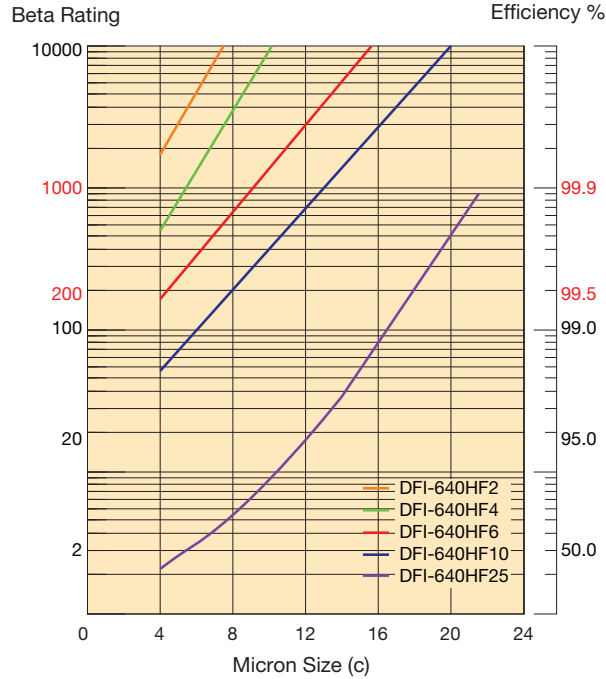

Single-pass tests run per SAE J1985  
@ 90 GPM - 5 mg/L BUGL

### DFI-640... Capacity

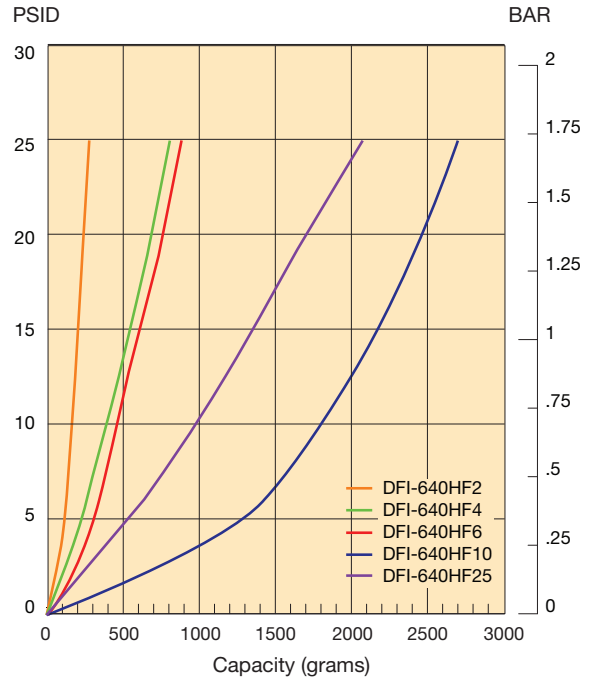

Multi-pass tests run per SAE J905  
@ 90 GPM to 25 PSID terminal - 20 mg/L BUGL

### DFI-640... Flow vs Pressure Loss

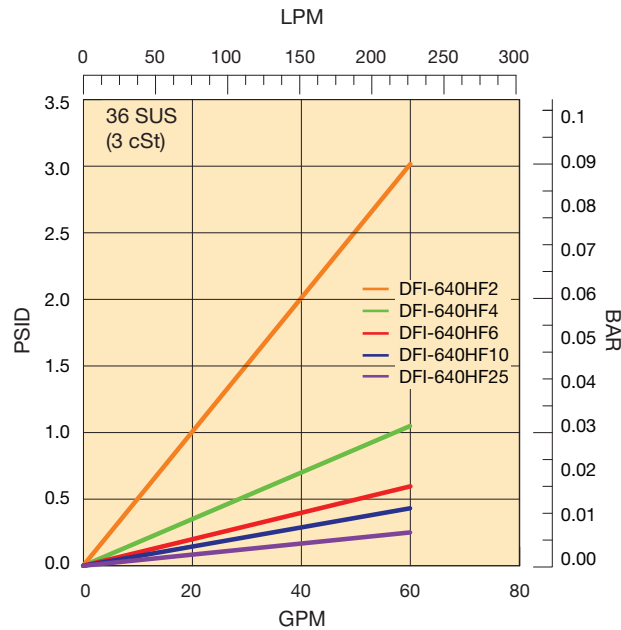

ISO 3968

# DFI Series

## Element Performance

### DFI-660... Efficiency

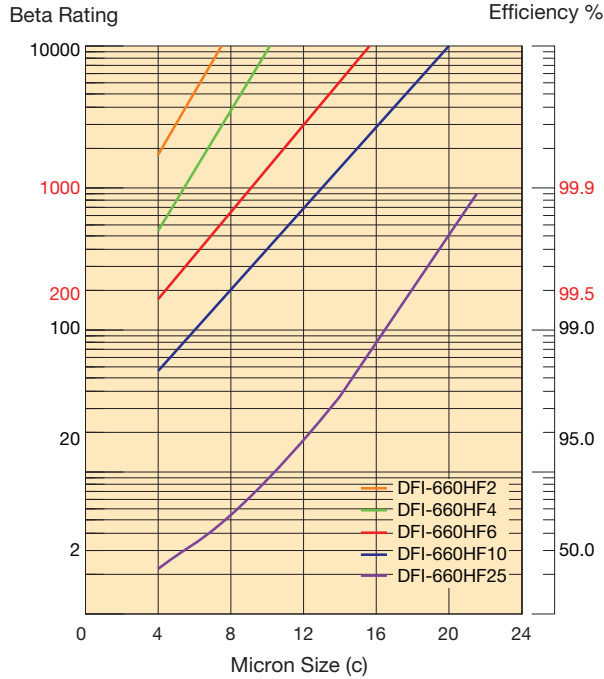

Single-pass tests run per SAE J1985  
@ 55 GPM - 5 mg/L BUGL

### DFI-660... Capacity

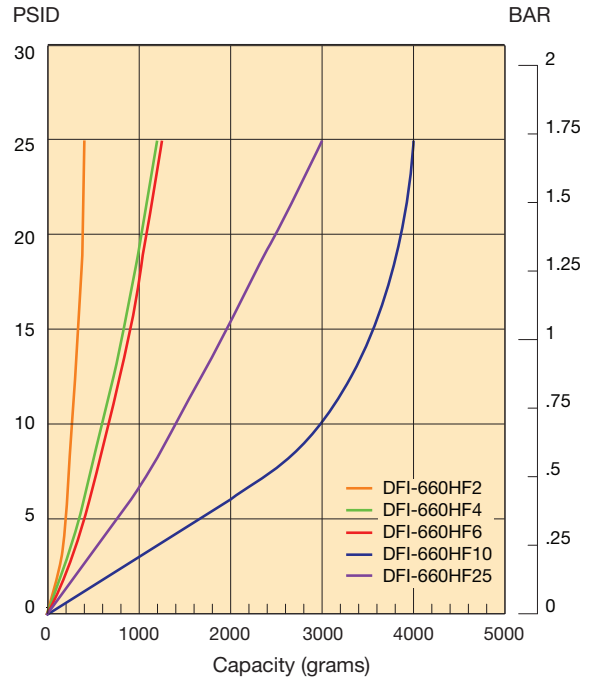

Multi-pass tests run per SAE J905  
@ 55 GPM to 25 PSID terminal - 75 mg/L BUGL

### DFI-660... Flow vs Pressure Loss

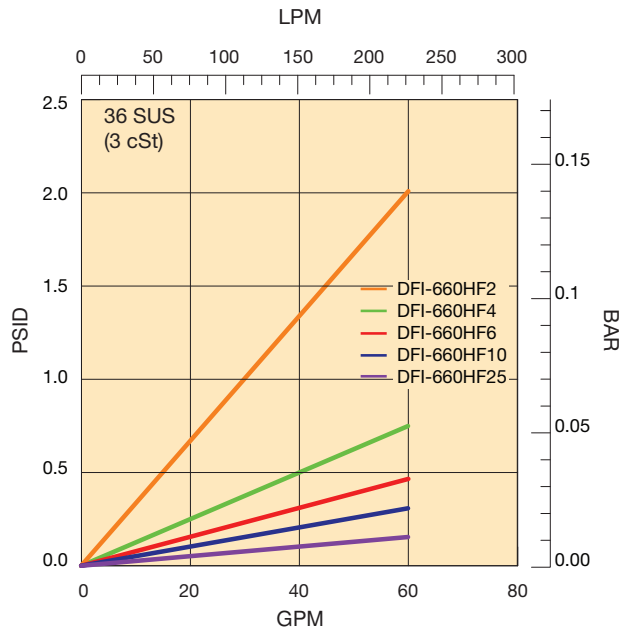

ISO 3968

# System Sizing

## Parker's SizeRight™ Filter System Selector



Element life is directly related to flow rates

SizeRight™ looks at more than just the cost of the filtration system and your flow rate needs. Factors we take into account when selecting the “right” system includes:

- incoming and outgoing fuel conditions
- frequency of change outs
- operating flow rates

In addition, we also consider incidental costs that our customers can incur when implement the filtration system:

- labor costs
- mean time between change outs
- miscellaneous costs during each change out

From these factors we can begin discussing the appropriate filtration solutions that customers should consider to truly determine the right system for their filtration needs.

Parker HFFD’s extensive bulk fuel handling experience and our state-of-the-art fuel testing laboratory have quantitatively proven that increased system/housing will allow for lower flow rates per filter while dramatically extending the service life of the elements. Systems “sized for life” commonly see a full repayment of the additional system cost through operating savings.

The faster you flow fuel through the particulate filter, the faster dirt will load your filter and the faster you will reach industry standard changeout differential pressure of 25 psid (1.7 bar). This also means more change outs will need to be done and each changeout incurs element costs, labor costs, opportunity/downtime costs and other miscellaneous costs.

Total cost of ownership should be considered when selecting your filtration system. Fuel condition and flow rate requirements only provide half of the equation. When cost is of concern, operating costs should be taken into effect as they make up a significant amount in the overall cost of acquisition and ultimately determining which filtration systems you really need.

## Application Guide

Filtration	Filter Series	Maximum Flow Rate gpm (lpm)							
		50(190)	150(568)	300(1136)	600(2271)	1200(2542)	2400(9095)	4800(18170)	9600(36340)
Particulate	DVF61/62	70 (265)							
	DVF8	176 (665)							
	DVF16	704 (2665)							
	DVF20/28	2688 (10174)							
	DVF36	4032 (15261)							
	DVF42/48	7392 (27979)							
	DVX1	55 (208)							
	DVX2	115 (435)							
	DVX3	175 (662)							
Coalescer/Separator	DV22	330 (1250)							
	DV28	660 (2498)							
	DV36	1540 (5828)							
	DV42	2100 (7949)							
	DVX1	30 (114)							
	DVX2	65 (246)							
	DVX3	100 (379)							
System	DFS1	300 (1240)							
	DFS2	520 (1960)							
	DFS3	2040 (7740)							

# DVF61/62 Series

## Vertical Filter Housings

For Use with AD-5 & DFO-5 Elements

These versatile housings are designed to meet various requirements: a fuel particulate filter, water absorption filter or a fuel polisher. Ideal for fuel dispensing applications.

The DVF61/62 filter assemblies are designed to meet the toughest hydrocarbon refueling conditions and are designed for easy element changeouts. Assemblies can be used on mobile refuelers or installed in refueling cabinets. These units can also be used for diesel fuel dispensing pumps, primary fuel filter/water elements of today's high pressure common-rail diesel injection systems, the DVF61/62 filter is used for fuel dispensing pumps or as a primary fuel filter/water absorber on large diesel engine applications.

DVF61/62 series filter assemblies were designed to meet the toughest conditions and offer ease of filter change outs. Featuring a band clamp closure, the DVF61 is ideal for limited space. The 4 swing bolt design of the DVF62 secures the head to the bowl.



DVF61

DVF62

### Filter Assemblies

Part Number	Description
DVF61	Filter housing using 12" element length
DVF62	Filter housing using 24" element length

### Replacement Elements

Type / Media		
<b>Particulate</b>	<i>DVF-61</i>	<i>DVF-62</i>
2 micron	DFO-512PLF2	DFO-524PLF2
5 micron	DFO-512PLF5	DFO-524PLF5
10 micron	DFO-512PLF10	DFO-524PLF10
25 micron	DFO-512PLF25	DFO-524PLF25
<b>Water Removal - Absorbing</b>	<i>DVF-61</i>	<i>DVF-62</i>
2 micron	AD-5122	AD-5242
5 micron	AD-5125	AD-5245
10 micron	AD-51210	AD-52410
25 micron	AD-51225	AD-52425

### Accessories

Part Number	Description
554Y020	Ball Valve, 1/2" NPT, Carbon Steel
CK-1488	Quick Release Hand Bolts (DVF62 only)
10678	Differential Pressure Gauge
G-0986	Cover Gasket, Nitrile
G-0986A	Cover Gasket, Fluorocarbon



# DVF61/62 Series

## Specifications

- Flow Rates:
  - DVF61 w/ Aquacon AD: 35 gpm (132 lpm), 20 gpm (75 lpm) recommended
  - DVF62 w/ Aquacon AD: 70 gpm (265 lpm), 40 gpm (151 lpm) recommended
- Max. Operating Pressure: 150 psi
- Inlet/Outlet connection: 1-1/2" NPT
- Closure Seal: Nitrile O-ring
- 1/8" brass petcock vent valve and 1/2" drain valve
- Material: Die cast aluminum head and closure clamp assembly; carbon steel shell with epoxy coated exterior and interior
- Weight:
  - DVF61: 10 lbs (4.54 kg)
  - DVF62: 16 lbs (7.26 kg)

### Optional Accessories

- Carbon Steel 1/2" NPT Ball Valve, with Mounting Nipple
- Quick release hand bolts (set of 4) to replace closure bolts (DVF62 only)
- Differential Pressure Gauge Assembly



Color Indicates Pressure Drop

**Green:** Clean  
0 - 15 psi

**Red:** Change  
16 - 25 psi

### DVF61

For use with AD-512 and DFO-512 Elements

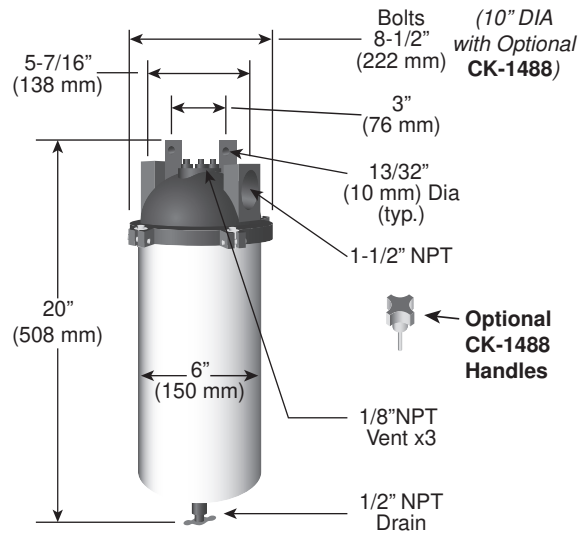

### DVF62

For use with AD-524 and DFO-524 Elements

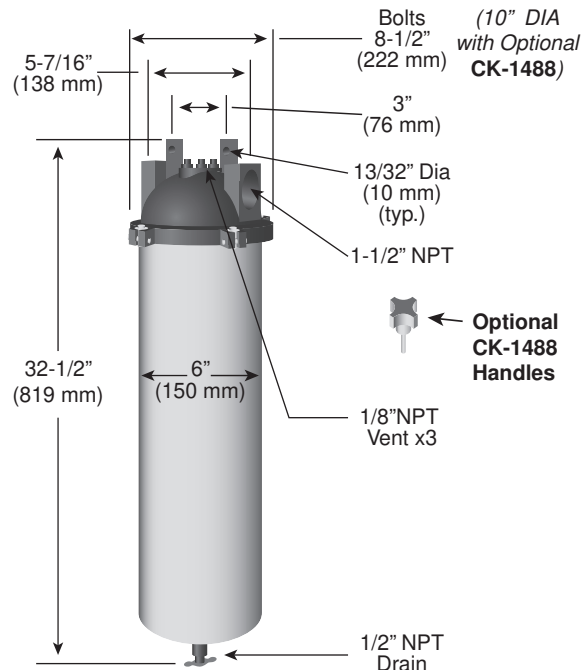

DVF62 has a longer body for areas and applications that require higher flow rate.

Drawings are not to scale. Dimensions are shown for estimating purposes only. Allow 6 inches (15.2 cm) below the vessel to safely remove the vessel to gain access to the element.

# DVF61

## Element Performance

### DFO-512... Efficiency

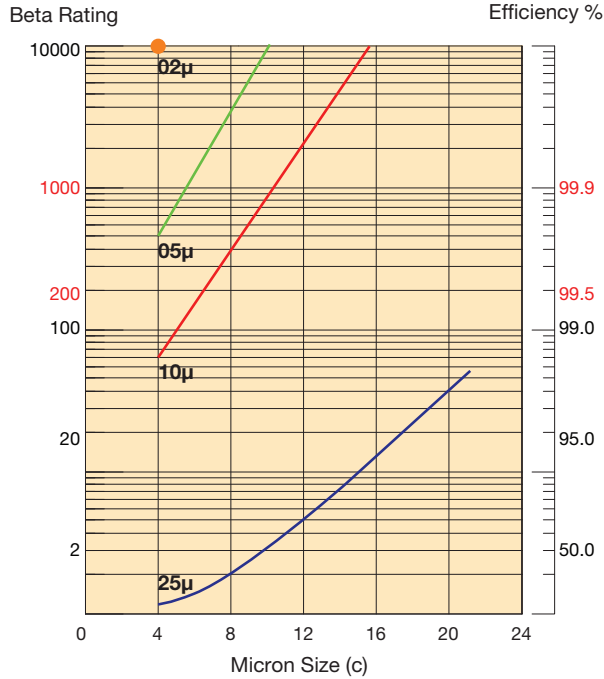

Single-pass tests run per SAE J1985  
@ 25 GPM - 5 mg/L BUGL

### DFO-512... Capacity

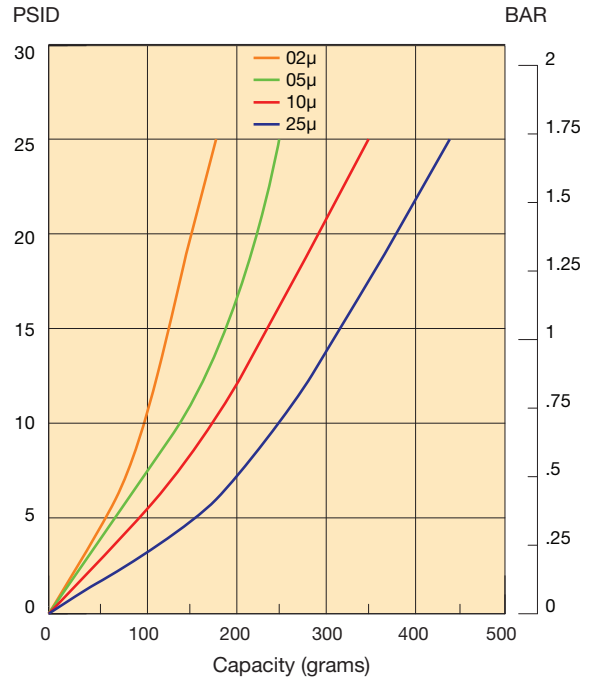

Multi-pass tests run per SAE J905  
@ 25 GPM to 25 PSID terminal - 20 mg/L BUGL

### DFO-512... Flow vs Pressure Loss

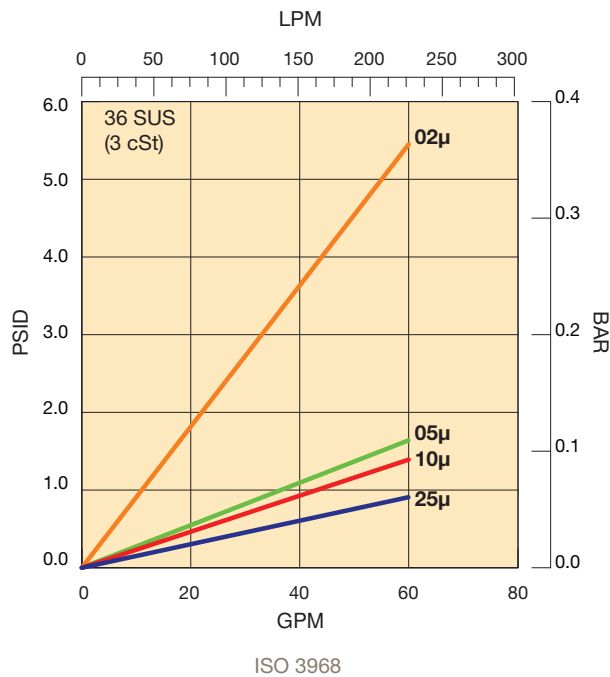

ISO 3968

### AD-51... Water Capacity

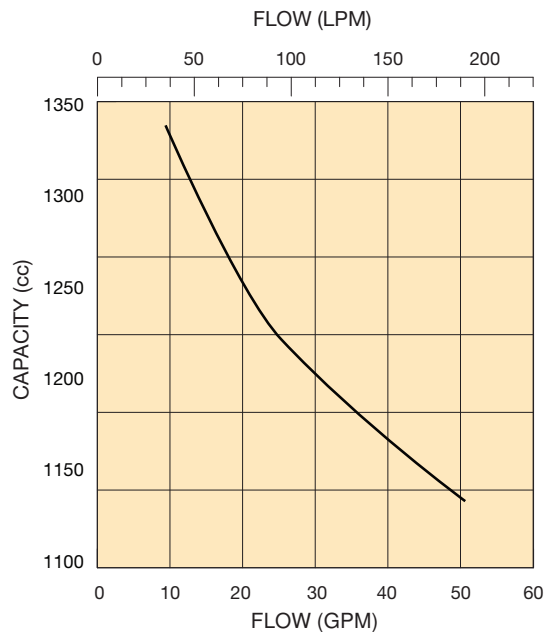

Internal test @ 25 GPM to  
25 PSID terminal - 100 ppm H<sub>2</sub>O

# DVF62

## Element Performance

### DFO-524... Efficiency

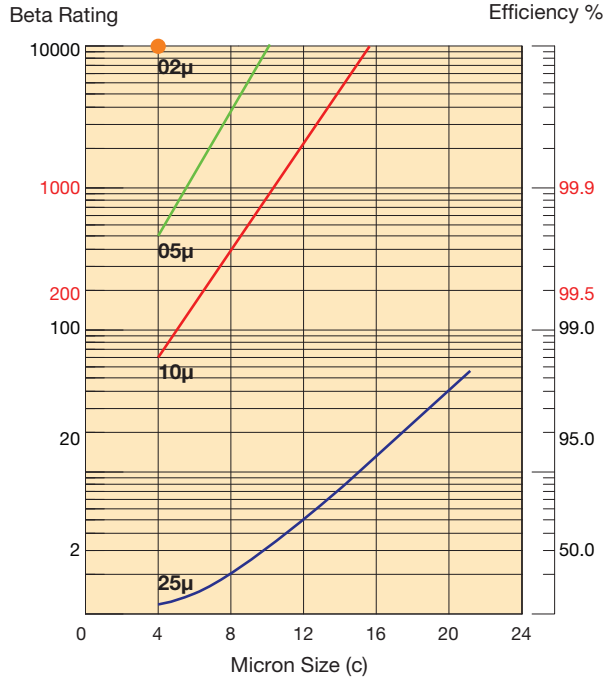

Single-pass tests run per SAE J1985  
@ 45 GPM - 5 mg/L BUGL

### DFO-524... Capacity

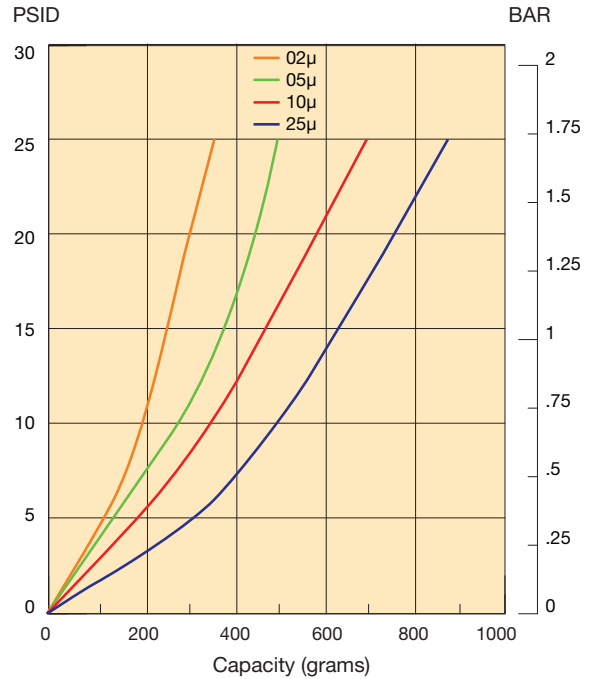

Multi-pass tests run per SAE J905  
@ 45 GPM to 25 PSID terminal - 20 mg/L BUGL

### DFO-524... Flow vs Pressure Loss

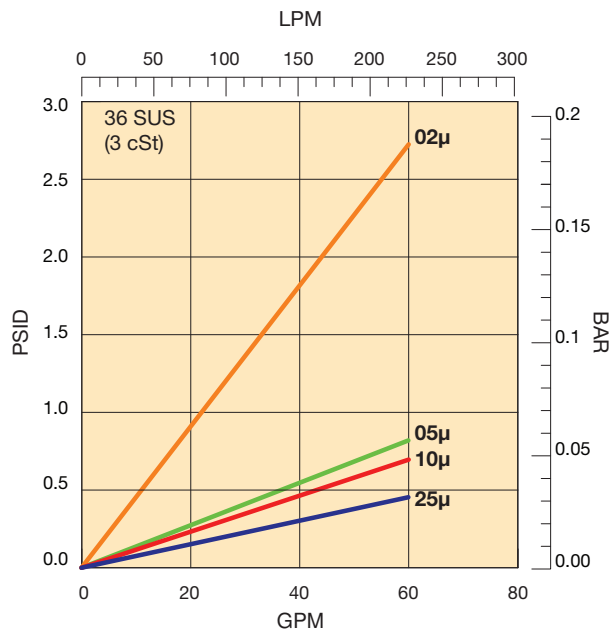

ISO 3968

### AD-52... Water Capacity

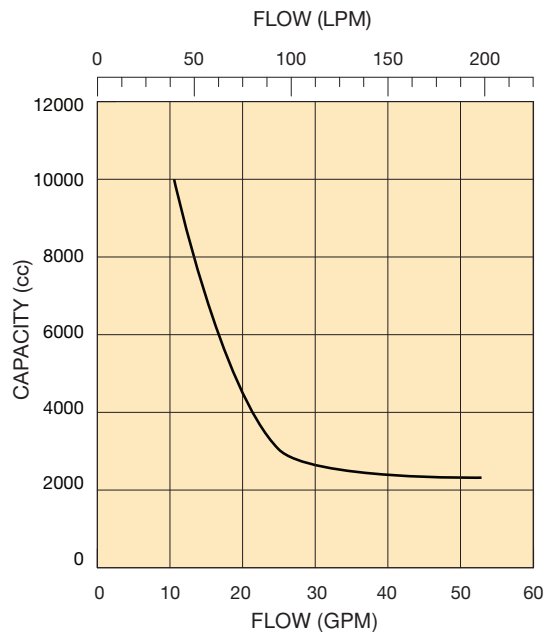

Internal test @ 45 GPM to  
25 PSID terminal - 100 ppm H<sub>2</sub>O

# DVX Series

## Housings for Diesel Fuel Filtration

For use with AD-6, DF0-6, D0-8/DS0-4 Elements

The Parker DVX Series is designed to be configured either in a particulate, water removal (absorption) or water removal (coalescing) arrangement. The DVX Series is also available in three different sizes to accommodate varying applications and flow requirements. This versatility makes the DVX Series applicable in many different market segments for superior fuel cleanliness. The DVX Series can be used in parallel to function in higher fuel requirements or where duplex arrangements are desired or required.

### Typical Applications

The DVX series offer many options which makes the unit perfect for many markets and applications. In the Natural Resources market, the DVX can be utilized in mining equipment, fuel transfer, fuel polishing, fuel delivery and on-engine filtration for larger engines. The Power Generation market offers several potential applications. From on-engine filtration for large engines to fuel transfer and polishing between day and bulk storage tanks, the DVX can provide superior clean dry fuel. The Transportation market also provides many different opportunities. Larger commercial marine vessels and Railroad engines all require superior fuel quality. The DVX series can be used to meet the fuel cleanliness requirement set by the engine manufacturers. Clean dry fuel allows the engines to operate at maximum efficiencies and maintain emission requirements.



# DVX Series

## Features

### Standard Design Features

- 1 ASME code powder coated carbon steel vessel (stamp on request)
- 2 250 psi (17.23 bar) design pressure
- 3 Swing bolt closure with nitrile seal
- 4 Leg Assembly
- 5 Differential pressure gauge assembly

### Options

- 6 Air eliminator
- 7 Drain valve
- 8 Pressure relief valve
- 9 Water probe
- 10 Water sight glass
- 11 CE Mark

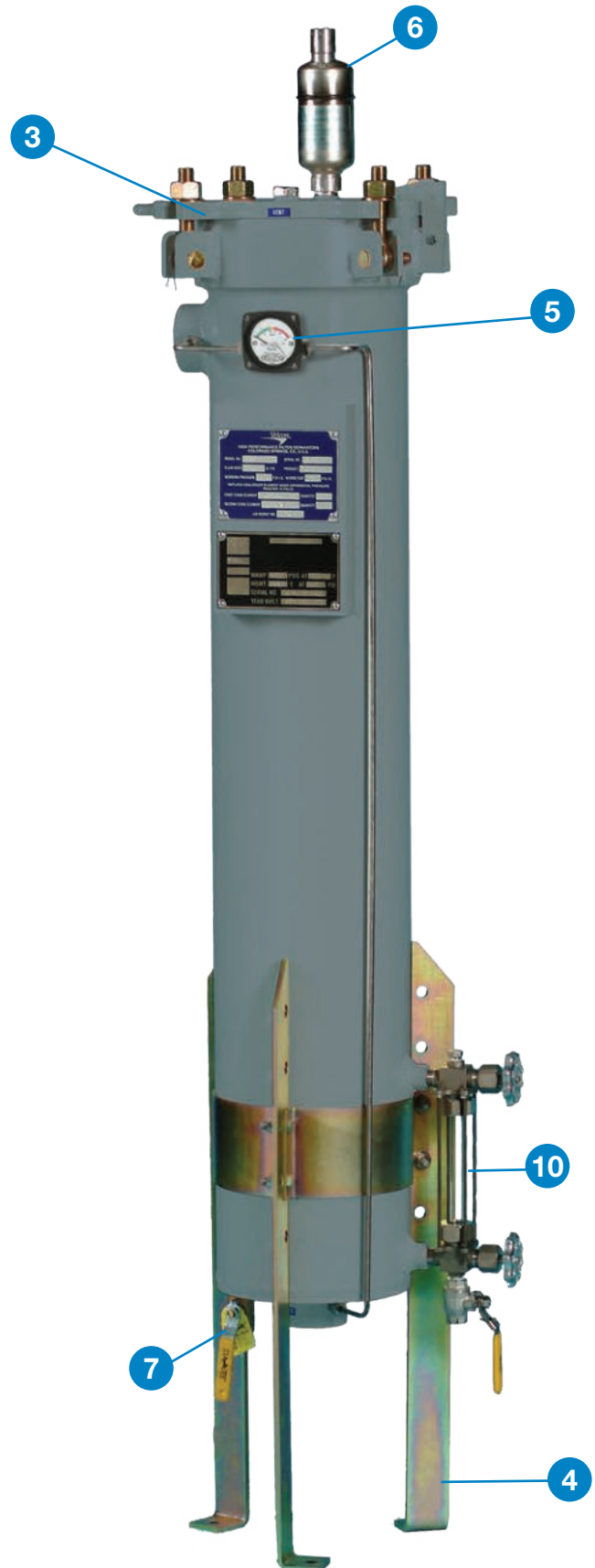

# DVX Series

## Specifications

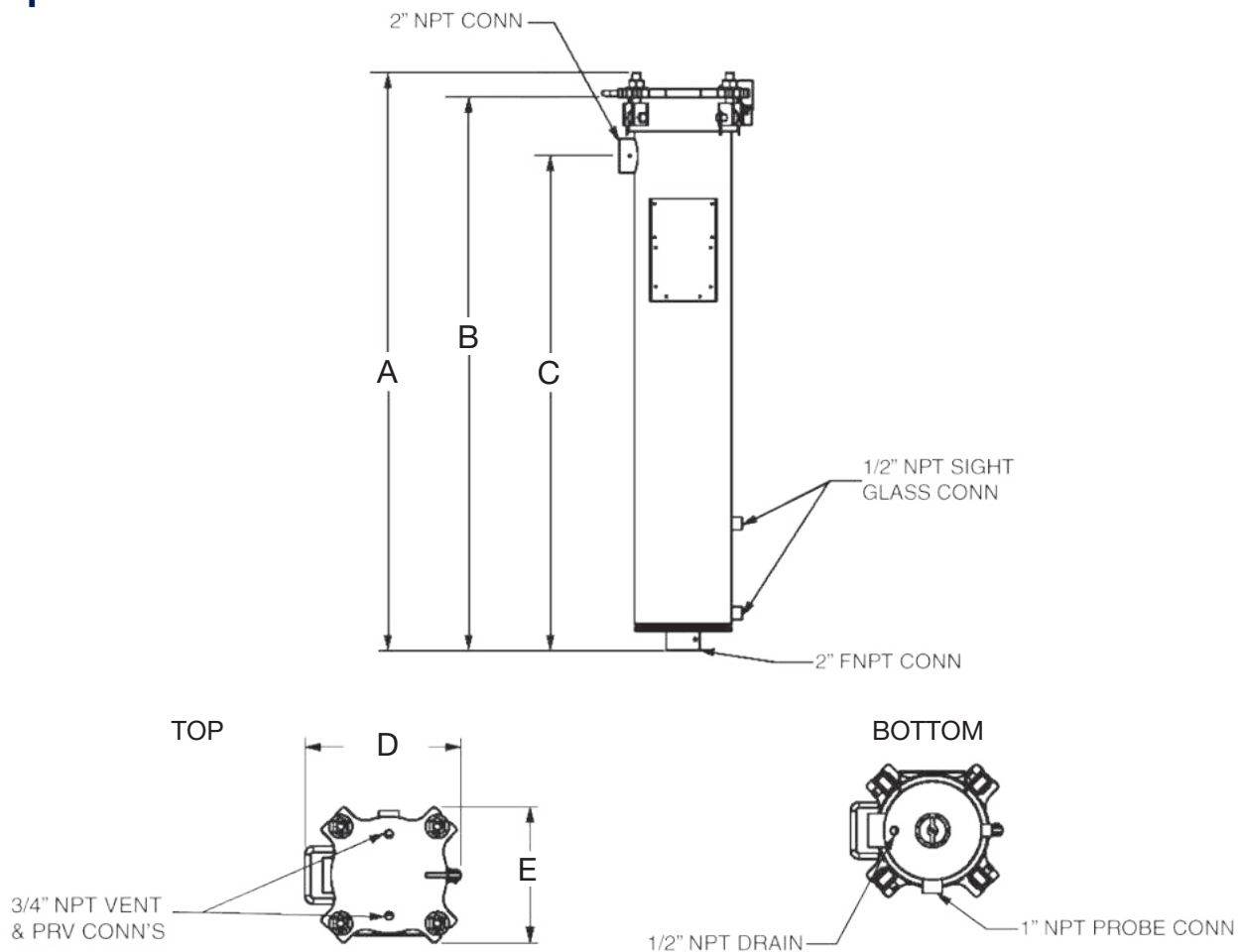

Model	Element	Flow Rates gpm (lpm)			Dimensions in (mm)					Dry Weight lbs (kgs)
		Max	Target	Fuel Processed Per Filter Change (US Gallons)	A	B	C	D	E	lbs.
DVX-1	DO-815/DSO-415	30 (114)	20 (76)	25000	36 (914)	34 1/4 (870)	29 1/8	13 7/16 (341)	11 5/8 (295)	110 (50)
	DFO-614 AD-614	55 (208)	30 (114)							
DVX-2	DO-830/DSO-430	65 (246)	40 (151)	50000	51 (1295)	49 (1244)	43 (1092)	13 7/16 (341)	11 5/8 (295)	125 (57)
	DFO-629 AD-629	115 (435)	65 (246)							
DVX-3	DO-844/DSO-444	100 (379)	60 (227)	76000	66 (1676)	64 1/4	59 1/16	13 7/16 (341)	11 5/8 (295)	150 (68)
	DFO-644 AD-644	175 (662)	100 (379)							

Dimensions shown are for estimating purposes only. For exact dimensional detail, obtain certified copy of vessel drawing.

# DVX Series

## Element Performance

### DFO-614... Efficiency

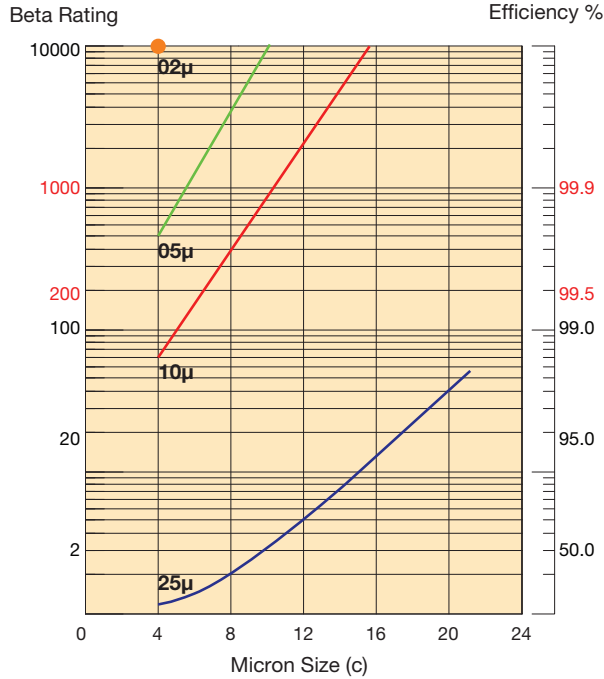

Single-pass tests run per SAE J1985  
@ 30 GPM - 5 mg/L BUGL

### DFO-614... Capacity

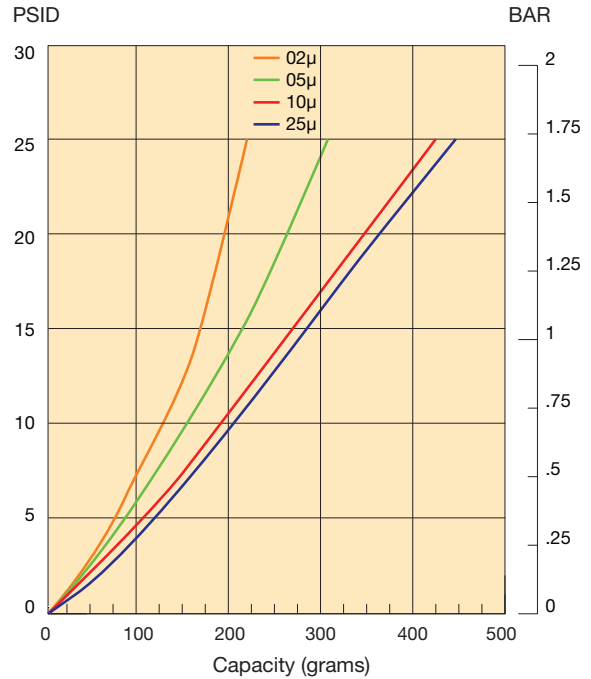

Multi-pass tests run per SAE J905  
@ 30 GPM to 25 PSID terminal - 20 mg/L BUGL

### DFO-614... Flow vs Pressure Loss

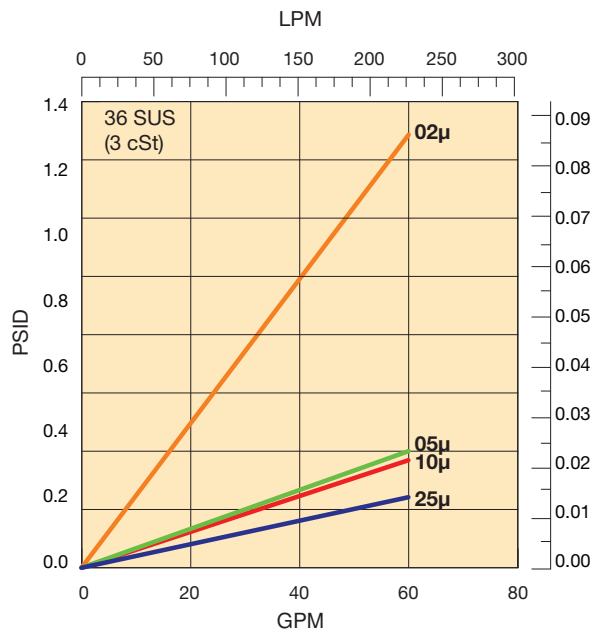

ISO 3968

### AD-61... Water Capacity

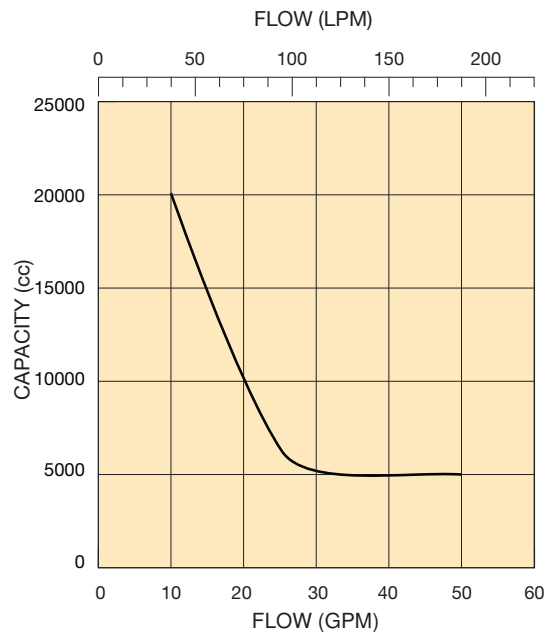

Internal test @ 30 GPM to  
25 PSID terminal - 100 ppm H<sub>2</sub>O

# DVX Series

## Element Performance

### DFO-629... Efficiency

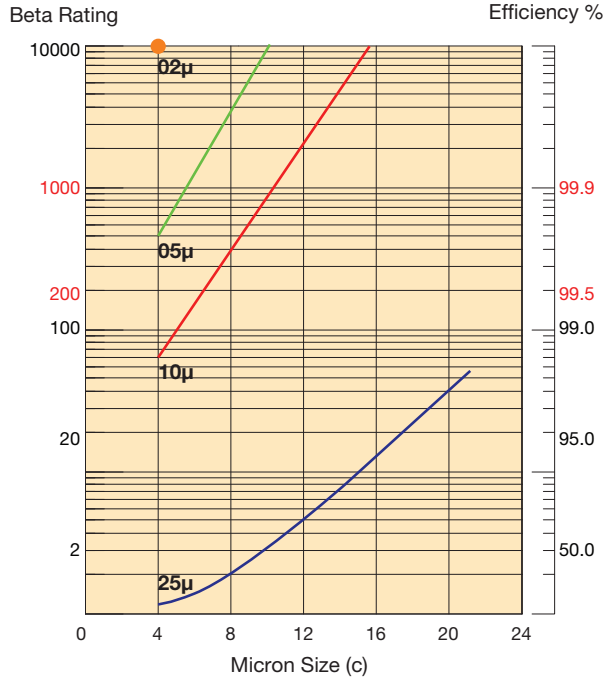

Single-pass tests run per SAE J1985  
@ 60 GPM - 5 mg/L BUGL

### DFO-629... Capacity

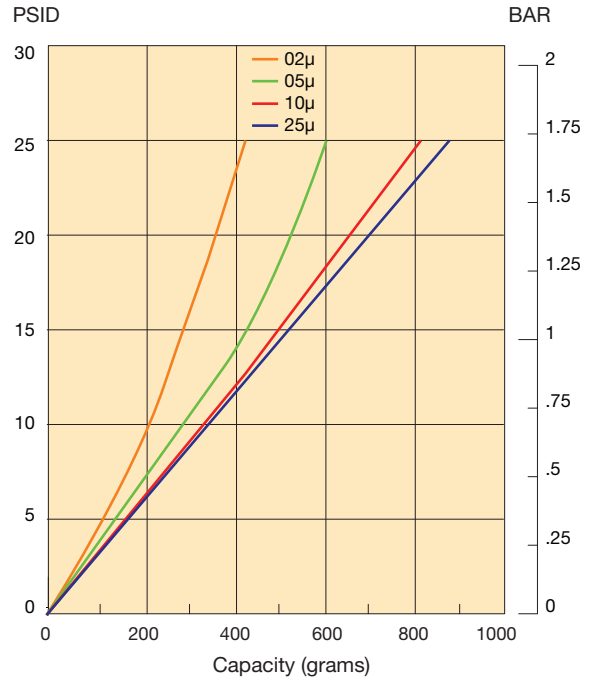

Multi-pass tests run per SAE J905  
@ 60 GPM to 25 PSID terminal - 20 mg/L BUGL

### DFO-629... Flow vs Pressure Loss

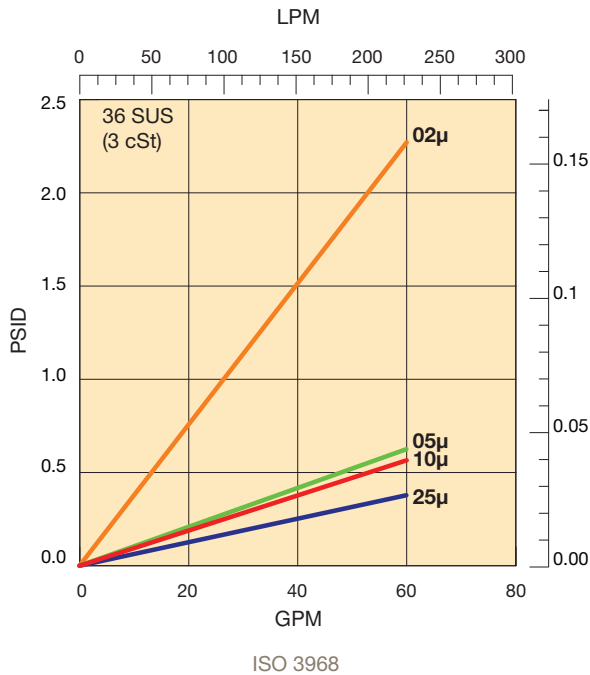

### AD-62... Water Capacity

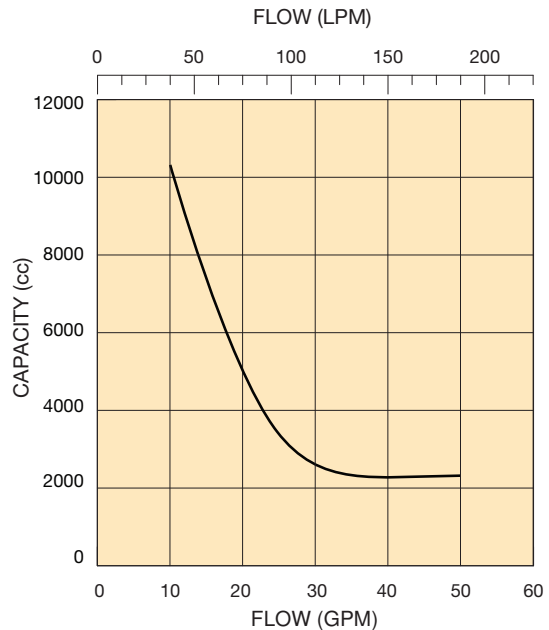

Internal test @ 60 GPM to  
25 PSID terminal - 100 ppm H<sub>2</sub>O

# DVX Series

## Element Performance

### DFO-644... Efficiency

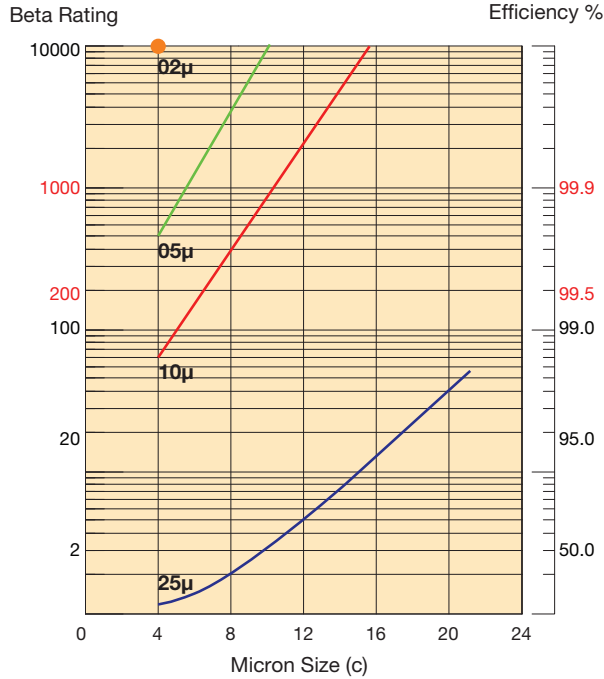

Single-pass tests run per SAE J1985  
@ 90 GPM - 5 mg/L BUGL

### DFO-644... Capacity

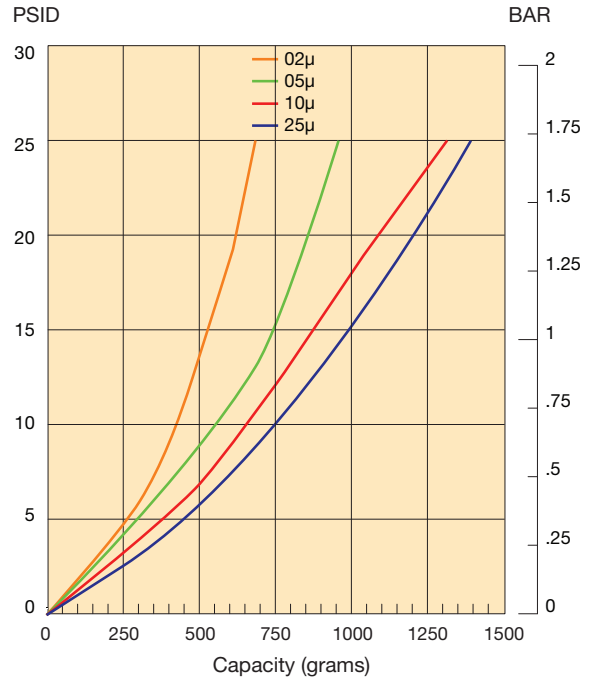

Multi-pass tests run per SAE J905  
@ 90 GPM to 25 PSID terminal - 20 mg/L BUGL

### DFO-644... Flow vs Pressure Loss

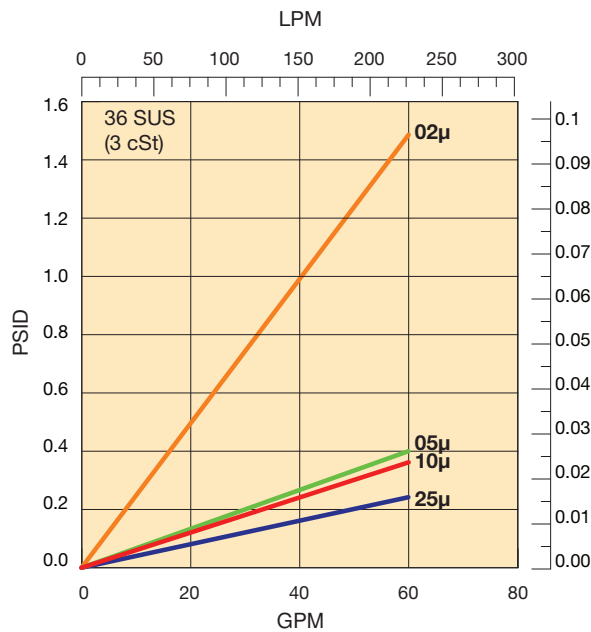

ISO 3968

### AD-64... Water Capacity

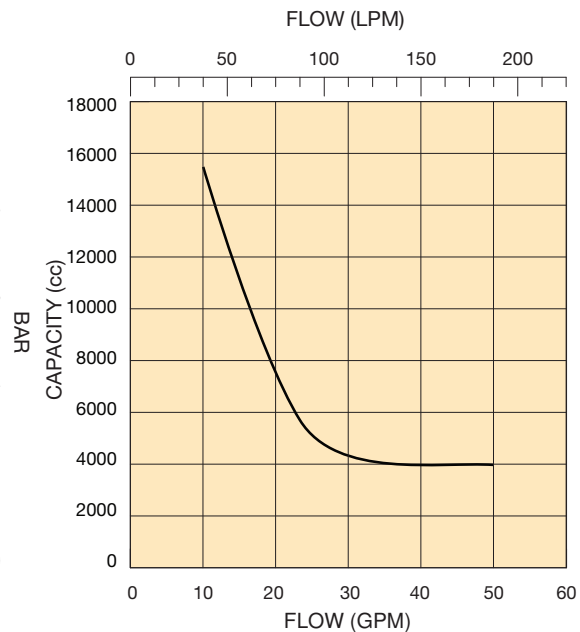

Internal test @ 90 GPM to  
25 PSID terminal - 100 ppm H<sub>2</sub>O

# DVX Series

## Vertical Filter Housings for Diesel Fuel Filtration

for Flows up to 175 gpm (662 lpm)

### How to Order

Select the desired symbol (in the correct position) to construct a model code. Example:

BOX 1	BOX 2	BOX 3	BOX 4	BOX 5	BOX 6	BOX 7	BOX 8
DVX	1	CS	X	B	DP	N32	1

BOX 1: Filter Series	
Symbol	Description
<b>DVX</b>	<b>Diesel Vertical Filter up to 175 gpm/662 lpm</b>

BOX 2: Element Length	
Symbol	Description
<b>1</b>	<b>14 in (355 mm)</b>
<b>2</b>	<b>29 in (737 mm)</b>
<b>3</b>	<b>44 in (1118 mm)</b>

BOX 3: Filtration Type <sup>1</sup>	
Symbol	Description
<b>P</b>	<b>Particulate</b>
<b>A</b>	<b>Water Absorption</b>
<b>CS</b>	<b>Coalescer/Separator</b>

BOX 4: Media Code <sup>2</sup>	
Symbol	Description
<b>X</b>	<b>No Element Installed (1 required)</b>

BOX 5: Seals	
Symbol	Description
<b>B</b>	<b>Nitrile</b>
V	Fluorocarbon

BOX 6: Indicator	
Symbol	Description
<b>P</b>	<b>Port Plugged</b>
<b>DP</b>	<b>Differential Pressure</b>
M2	Visual Automatic Reset

BOX 7: Ports	
Symbol	Description
<b>N32</b>	<b>2" NPT</b>
A2	2" 150# RF ANSI

BOX 8: Options <sup>3</sup>	
Symbol	Description
<b>1</b>	<b>None</b>
AE	Air Eliminator
DV	Drain Valve
NL	No Legs
PR	Pressure Relief Valve 250#
SG	Site Gauge

**Please note the bolded options reflect standard options with reduced lead-time.**

Notes:

- If choosing "CS", "5", "10" and "25" are the only available filtration rating options.
- Use the chosen codes from Box 2 and Box 3, along with the desired filtration type/rating and separator material to select the correct element from the tables below. **Example:** For model DVX**1**PXBPN321 with 10 micron particulate, element DFO-614PLF10 would be required.
- Select one or more options, as desired.

### Replacement Elements

Type / Media	Element Length 1	Element Length 2	Element Length 3
<b>Particulate</b>			
2 micron	DFO-614PLF2	DFO-629PLF2	DFO-644PLF2
5 micron	DFO-614PLF5	DFO-629PLF5	DFO-644PLF5
10 micron	DFO-614PLF10	DFO-629PLF10	DFO-644PLF10
25 micron	DFO-614PLF25	DFO-629PLF25	DFO-644PLF25

Water Absorption			
2 micron	AD-6142	AD-6292	AD-6442
5 micron	AD-6145	AD-6295	AD-6445
10 micron	AD-61410	AD-62910	AD-64410
25 micron	AD-61425	AD-62925	AD-64425

Coalescer	Separator						
5 micron	Pleated Cellulose	DO-815D5	DSO-415PL	DO-830D5	DSO-430PL	DO-844D5	DSO-444PL
10 micron		DO-815D10		DO-830D10		DO-844D10	
25 micron		DO-815D25		DO-830D25		DO-844D25	

Element Mounting Kits	DVX-1	DVX-2	DVX-3
For A or P (Box 3)	VX1-AVKIT	VX2-AVKIT	VX3-AVKIT
For CS (Box 3)	VX1-FSKIT	VX2-FSKIT	VX3-FSKIT

# DVF Series

## Vertical Filter Housings

For Use with AD-6 & DFO-6 Elements

Clean fuel is more important than ever with HPCR (High Pressure Common Rail) systems becoming the standard in diesel engines. Contaminants as small as 2 microns can lead to a loss of fuel economy, a less efficient engine, down time, component failure, catastrophic engine failure and potentially the rejection of a warranty claim from the engine manufacturer. Currently, the ISO code of 18/16/13 by some engine manufacturers require fuel to be cleaner than some Aviation Military fuel standards. The standard DVF series offers several options in element micron ratings, including water absorption and a range of single vessel flows from 176 gallons per minute to 7,392 gallons per minute. Parker's DVF series of vessels are design to meet today's engine manufacturers requirements for clean fuel while allowing older engines to operate at maximum efficiencies. The DVF series filters all types of diesel fuels from standard diesel to 100% biodiesel.



### Typical Applications

The DVF series offers many options which makes it perfect for many markets and applications. In the Natural Resources market, the DVF can be utilized in mining equipment, fuel transfer, fuel polishing and fuel delivery. Opportunities exist for small and large fuel terminals. The Power Generation market offers several potential applications. Fuel transfers from terminals and polishing of bulk storage tanks, the DVF will provide superior clean fuel. The Transportation market also provides many different opportunities. Larger commercial marine vessels can filter fuel as it is offloaded from land or sea suppliers. Railroad terminals can filter fuel as it is transferred to maintain superior fuel quality. The DVF series can be used to meet the fuel cleanliness requirement set by the engine manufactures. Clean fuel allows the engines to operate at maximum efficiencies and maintain emission requirements.



# DVF Series

## Features

### Standard Design Features

- 1 150 psi (10.34 bar) welded steel ASME Code construction (stamp on request)
- 2 Epoxy coated interior, primed exterior
- 3 Swing bolt closure with nitrile cover seals
- 4 Inlet/Outlet sample ports
- 5 Hydraulic lifting davit<sup>1</sup>

### Options

- 6 Automatic air eliminator
- 7 Pressure relief valve
- 8 Differential pressure gauge
- 9 Drain valve(s)
- 10 Choice of micron rating from 2 to 25 microns
- 11 Choice of pleated or depth type media



1. DVF16 and DVF20 Series vessels have flat covers. DVF16 Series vessels do not have hydraulic lift jacks.

# DVF Series

## Specifications

Figure 1

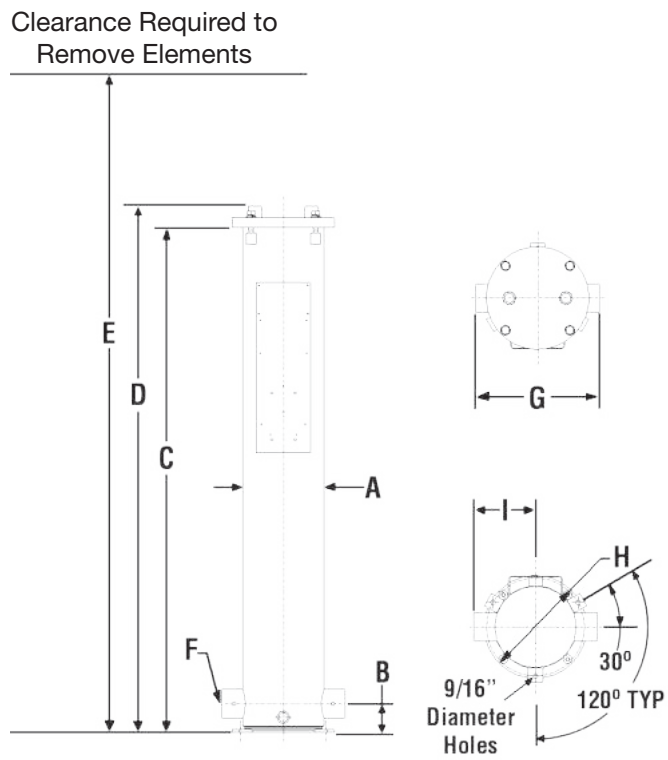

Clearance Required to Remove Elements

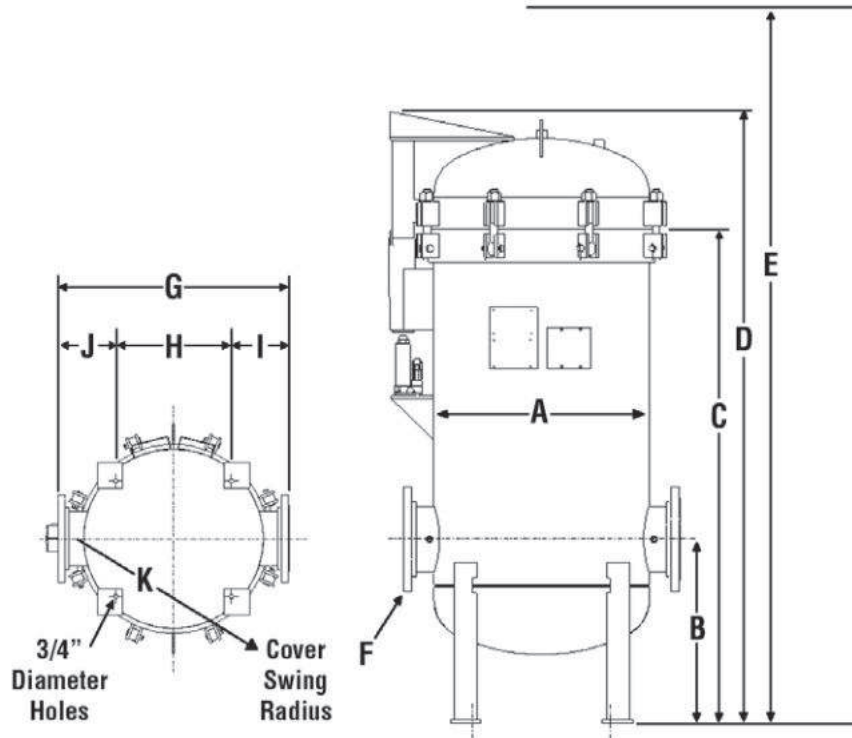

Figure 2

# DVF Series

## Specifications

Model	Flow Rate Range gpm (lpm)			Length in (mm)	Qty of Elements	Fig. No.	Dimensions in (mm)		
	Max	Target	Fuel Processed Per Filter Change (US Gallons)				A	B	C
DVF829	116 (439)	65 (247)	50000	29 (737)	1	1	8.63 (219)	3 (76)	57.06 (991)
DVF844	176 (665)	99 (375)	75000	44 (1118)	1	1	8.63 (219)	3 (76)	57.06 (1449)
DVF1629	464 (1756)	261 (988)	200000	29 (737)	4	1	16 (406)	15 (381)	52.81 (1341)
DVF1644	704 (2665)	396 (1499)	300000	44 (1118)	4	1	16 (406)	15 (381)	66.75 (1695)
DVF2044	1056 (3997)	594 (2248)	450000	44 (1118)	6	1	20 (508)	19.5 (495)	74.63 (1895)
DVF2444	1408 (5329)	792 (2998)	600000	44 (1118)	8	2	24 (610)	21 (533)	65 (1651)
DVF2456	1792 (6783)	1008 (3815)	770000	56 (1422)	8	2	24 (610)	21 (533)	77 (1956)
DVF2844	2112 (7994)	1188 (4497)	900000	44 (1118)	12	2	28 (711)	24 (610)	64.38 (1635)
DVF2856	2688 (10174)	1512 (5723)	1110000	56 (1422)	12	2	28 (711)	24 (610)	76.38 (1940)
DVF3644	3168 (11991)	1782 (6745)	1400000	44 (1118)	18	2	36.63 (930)	26 (660)	64.38 (1635)
DVF3656	4032 (15261)	2268 (8584)	1700000	56 (1422)	18	2	36.63 (930)	26 (660)	76.38 (1940)
DVF4244	4752 (17986)	2673 (10117)	2000000	44 (1118)	27	2	42.75 (1086)	28 (711)	66 (1676)
DVF4256	6048 (22892)	3402 (12877)	2600000	56 (1422)	27	2	42.75 (1086)	28 (711)	78 (1981)
DVF4856	7392 (27979)	4158 (15738)	3100000	56 (1422)	33	2	48 (1219)	29 (737)	80 (2032)

Model	Dimensions in (mm)								Wt. w/Skid lbs (kgs)	Volume US gal (ltr.)
	D	E	F	G	H	I	J	K		
DVF829	41.13 (1045)	68 (1727)	2 (51)	13 (330)	10.38 (264)	6.5 (165)			265 (120)	8 (30)
DVF844	59.44 (1510)	101 (2565)	2 (51)	13 (330)	10.38 (264)	6.5 (165)			305 (138)	11 (42)
DVF1629	55.81 (1418)	82 (2083)	4 (102)	24.25 (616)	9 (229)	7.63 (194)	7.63 (194)	18.44 (468)	560 (254)	35 (132)
DVF1644	69.75 (1772)	110 (2794)	4 (102)	24.25 (616)	9 (229)	7.63 (194)	7.63 (194)	18.44 (468)	620 (281)	50 (189)
DVF2044	80.44 (2043)	118 (2997)	6 (152)	28 (711)	13 (330)	7.5 (191)	7.5 (191)	26 (660)	1100 (499)	90 (341)
DVF2444	72 (1829)	112 (2845)	6 (152)	32 (813)	15 (381)	8 (203)	8 (203)	32 (813)	1300 (590)	120 (454)
DVF2456	84 (2134)	122 (3099)	6 (152)	32 (813)	15 (381)	8 (203)	8 (203)	32 (813)	1350 (612)	150 (568)
DVF2844	79.75 (2026)	108 (2743)	8 (203)	36 (914)	18 (457)	9 (229)	9 (229)	35 (889)	1600 (726)	165 (625)
DVF2856	91.75 (2330)	120 (3048)	8 (203)	36 (914)	18 (457)	9 (229)	9 (229)	35 (889)	1750 (794)	200 (757)
DVF3644	84 (2134)	109 (2769)	10 (254)	48 (1219)	23 (584)	12.5 (318)	12.5 (318)	44 (1118)	2250 (1021)	290 (1098)
DVF3656	96 (2438)	121 (3073)	10 (254)	48 (1219)	23 (584)	12.5 (318)	12.5 (318)	44 (1118)	2400 (1089)	350 (1325)
DVF4244	87.38 (2219)	110 (2794)	12 (305)	54 (1372)	28 (711)	13 (330)	13 (330)	52.25 (1327)	3800 (1724)	400 (1514)
DVF4256	98.38 (2499)	122 (3099)	12 (305)	54 (1372)	28 (711)	13 (330)	13 (330)	52.25 (1327)	4000 (1814)	475 (1798)
DVF4856	108 (2743)	165 (4191)	14 (356)	66 (1676)	36.5 (927)	14.75 (375)	14.75 (375)	65 (1651)	4400 (1996)	630 (2385)

- For higher viscosity fluids or operating in highly variable temperature conditions, consult your Parker Representative.
- DVF Series are designed to accommodate our standard 6 in. O.D., 3½ in. I.D. Elements including Parker's DFO, DI, DSO, and Aquacon® AD.
- DVF16 and DVF20 Series vessels have flat covers. DVF16 Series vessels do not have hydraulic lift jacks.
- In applications where increased dirt contamination is present, it may be desirable to oversize filtration equipment. Contact Parker for oversizing recommendations.
- Actual flow rates may vary based on field conditions.
- Fuel processed is based on target flow rate and 21/18/16 ISO 4406 or 5 mg/liter incoming contamination levels. Field conditions will vary and actual results may be different than these estimates.

Dimensions shown are for estimating purposes only. For exact dimensional detail, obtain certified copy of vessel drawing.

# DVF Series

## Element Performance

### DFO-629... Efficiency

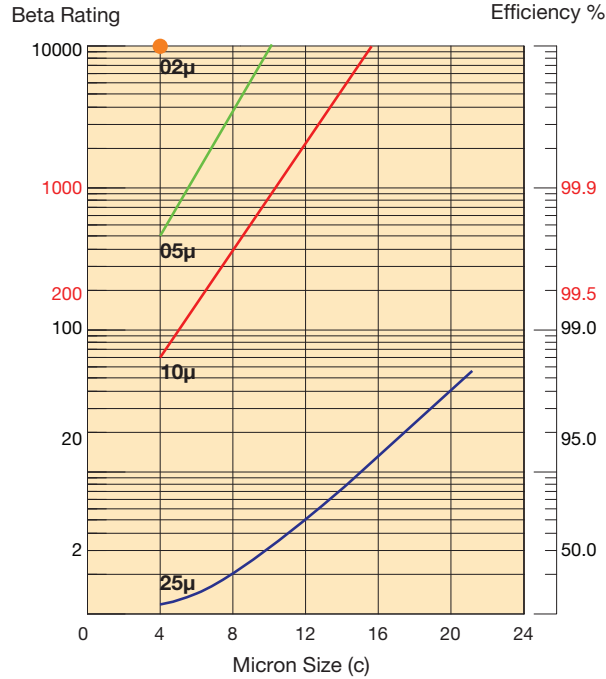

Single-pass tests run per SAE J1985  
@ 60 GPM - 5 mg/L BUGL

### DFO-629... Capacity

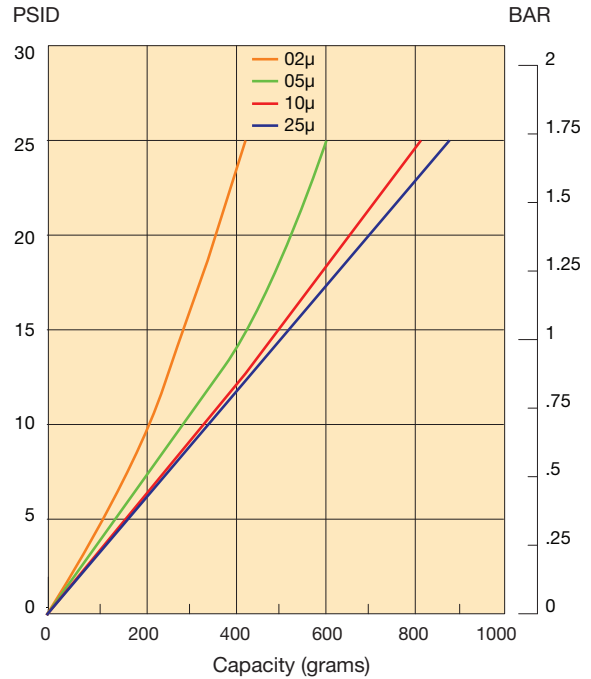

Multi-pass tests run per SAE J905  
@ 60 GPM to 25 PSID terminal - 20 mg/L BUGL

### DFO-629... Flow vs Pressure Loss

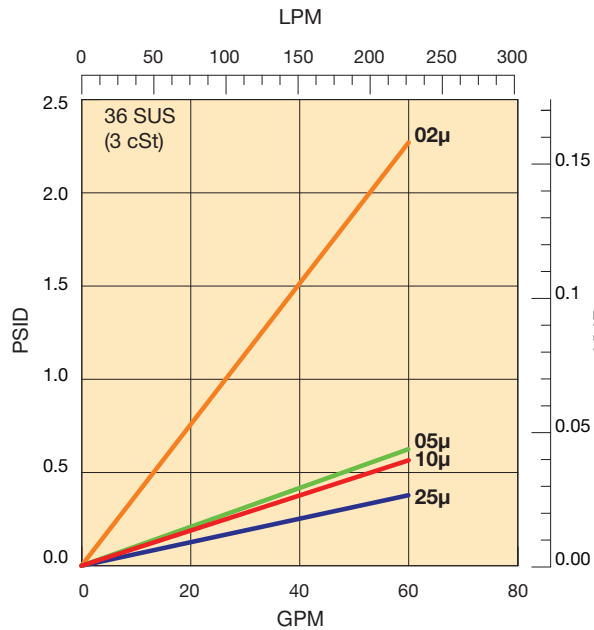

ISO 3968

### AD-62... Water Capacity

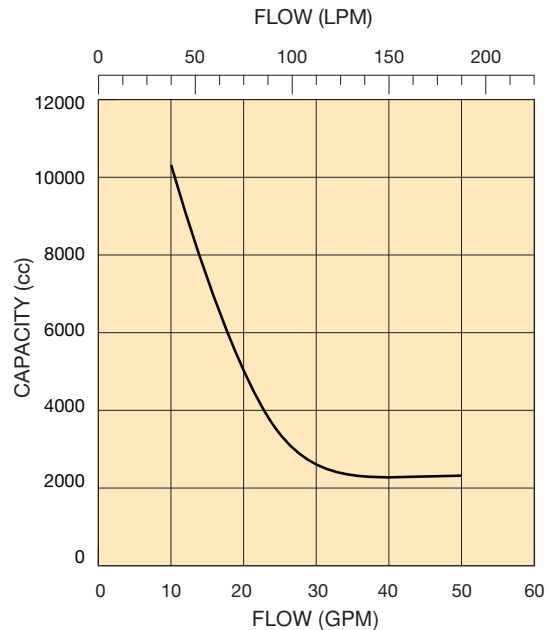

Internal test @ 60 GPM to  
25 PSID terminal - 100 ppm H<sub>2</sub>O

# DVF Series

## Element Performance

### DFO-644... Efficiency

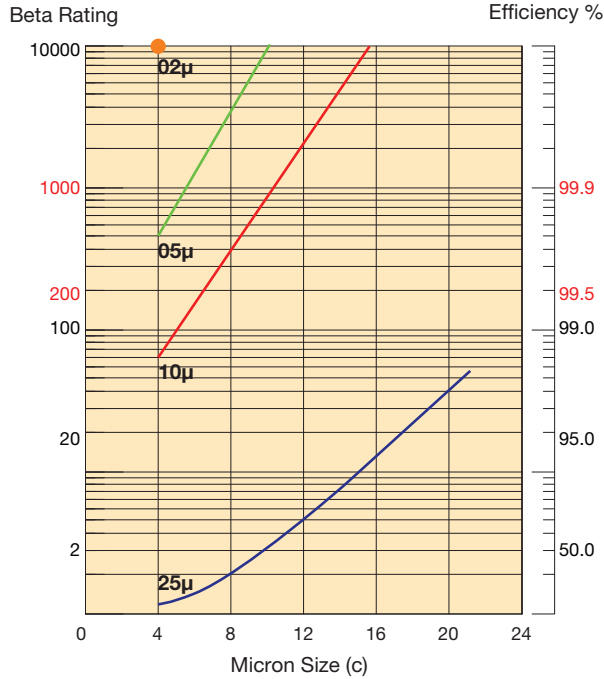

Single-pass tests run per SAE J1985  
@ 90 GPM - 5 mg/L BUGL

### DFO-644... Capacity

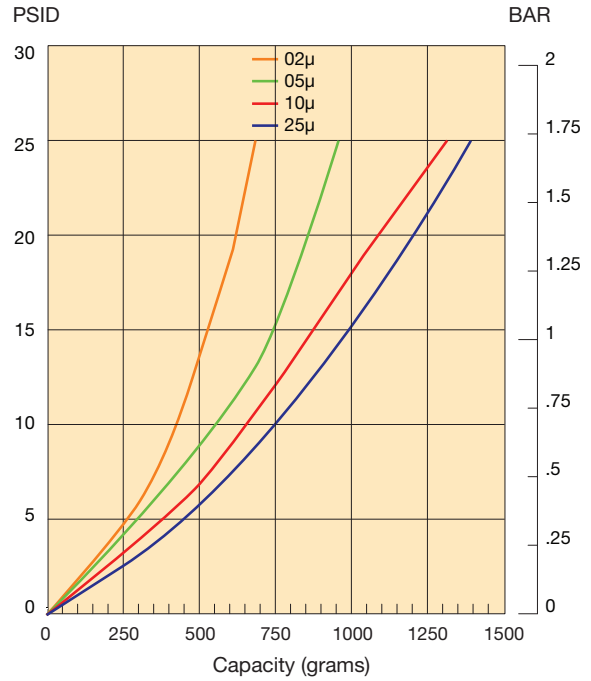

Multi-pass tests run per SAE J905  
@ 90 GPM to 25 PSID terminal - 20 mg/L BUGL

### DFO-644... Flow vs Pressure Loss

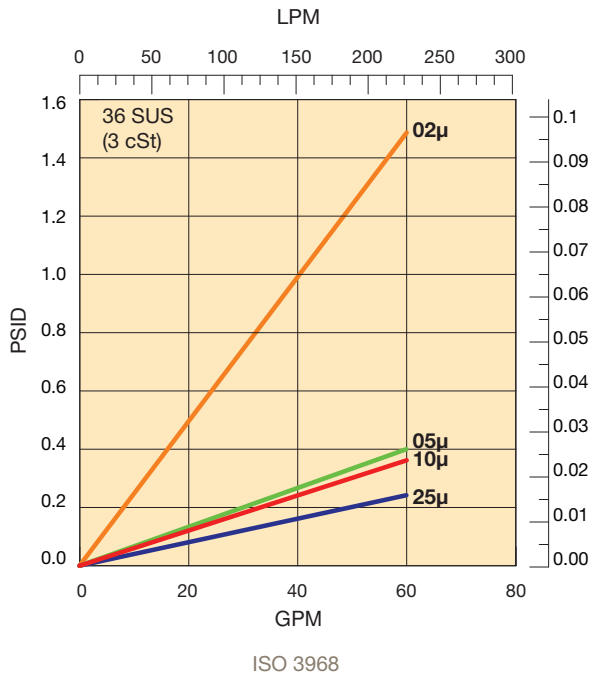

ISO 3968

### AD-64... Water Capacity

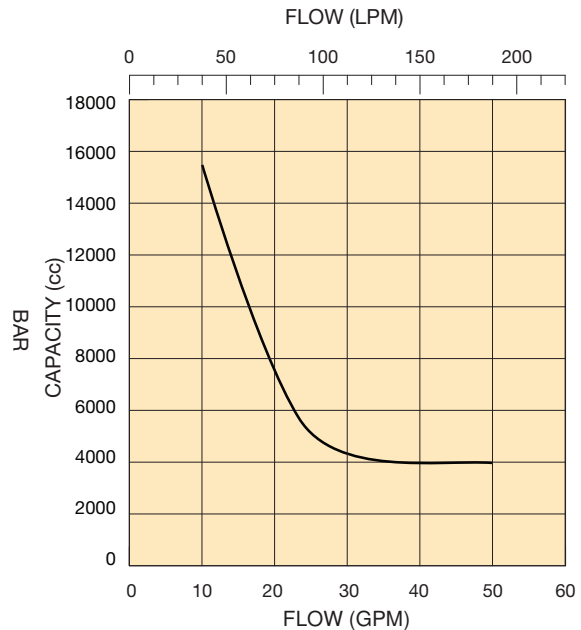

Internal test @ 90 GPM to  
25 PSID terminal - 100 ppm H<sub>2</sub>O

# DVF Series

## Element Performance

### DFO-656... Efficiency

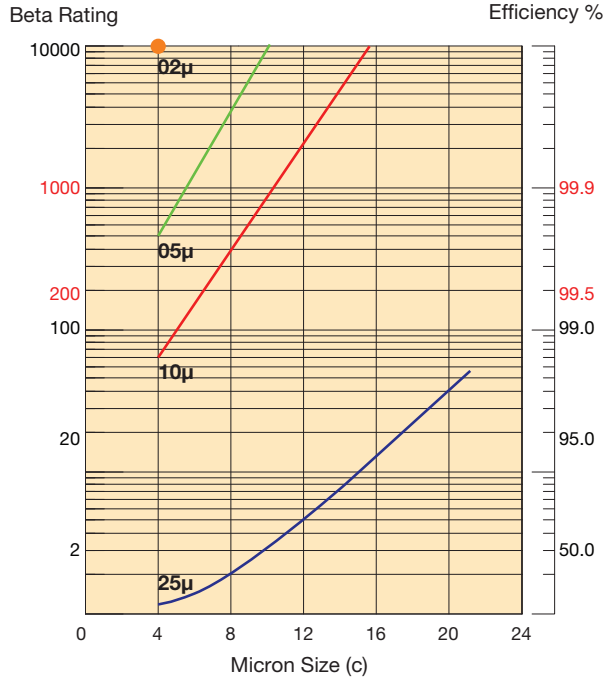

Single-pass tests run per SAE J1985  
@ 115 GPM - 5 mg/L BUGL

### DFO-656... Capacity

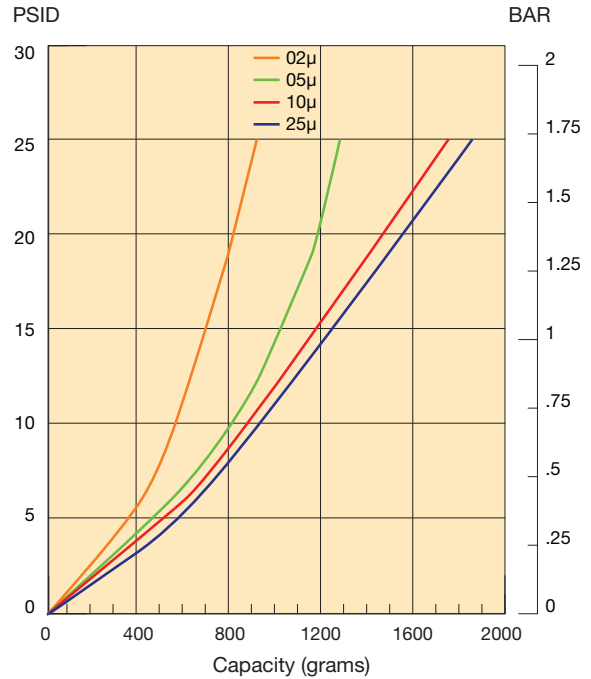

Multi-pass tests run per SAE J905  
@ 115 GPM to 25 PSID terminal - 20 mg/L BUGL

### DFO-656... Flow vs Pressure Loss

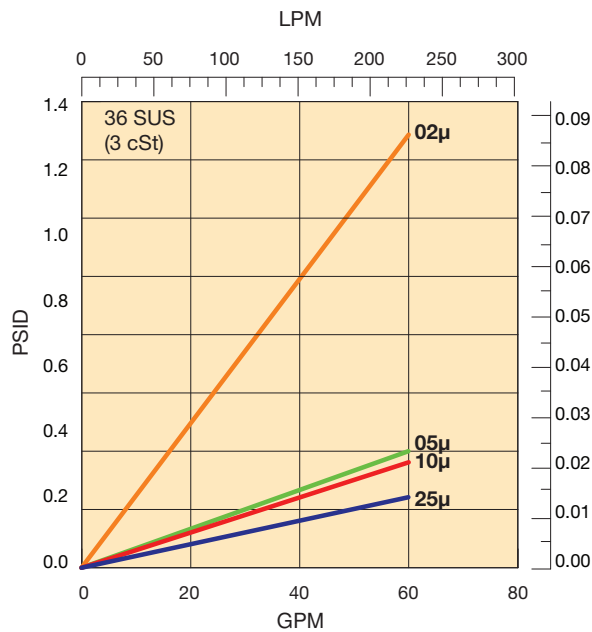

ISO 3968

### AD-65... Water Capacity

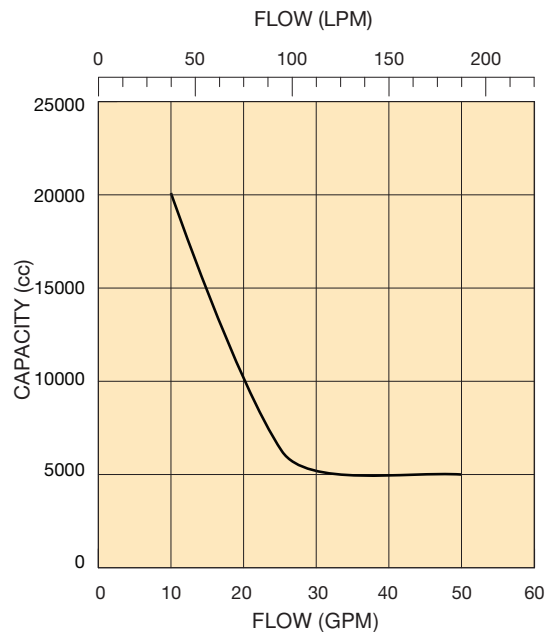

Internal test @ 115 GPM to  
25 PSID terminal - 100 ppm H<sub>2</sub>O

# DVF8 Series

## Vertical Filter Housings for use with DFO-6 and AD-6 Elements for Flows up to 176 gpm (665 lpm)

### How to Order

Select the desired symbol (in the correct position) to construct a model code. Example:

BOX 1	BOX 2	BOX 3	BOX 4	BOX 5	BOX 6	BOX 7	BOX 8
DVF8	29	P	X	B	DP	A2	1

BOX 1: Filter Series	
Symbol	Description
DVF8	Diesel Vertical Filter up to 176 gpm/750 lpm

BOX 4: Media Code	
Symbol	Description
X	No Element Installed (1 required) <sup>1</sup>

BOX 7: Ports	
Symbol	Description
A2	2" 150# RF ANSI

BOX 2: Element Length	
Symbol	Description
29	29 in (727 mm)
44	44 in (1118 mm)

BOX 5: Seals	
Symbol	Description
B	Nitrile
V	Fluorocarbon

BOX 8: Options <sup>2</sup>	
Symbol	Description
1	None
AE	Air Eliminator
DV	Drain Valve
PR	Pressure Relief Valve 150#

BOX 3: Filtration Type	
Symbol	Description
P	Particulate
A	Water Absorption

BOX 6: Pressure Gauge	
Symbol	Description
P	Port Plugged
DP	Differential Pressure
M2	Visual Automatic Reset

**Please note the bolded options reflect standard options with reduced lead-time.**

Notes:

- Use the chosen codes from Box 2 and Box 3, along with the desired filtration rating to select the correct element from the tables below. **Example:** For model DVF8**29P**XBPA21, element DFO-629PLF10TB would be required.
- Select one or more options, as desired.

### Replacement Elements

Type / Media			
Particulate	<b>29 in (737 mm)</b>	<b>44 in (1118 mm)</b>	
	2 micron	DFO-629PLF2TB	DFO-644PLF2TB
	5 micron	DFO-629PLF5TB	DFO-644PLF5TB
	10 micron	DFO-629PLF10TB	DFO-644PLF10TB
	25 micron	DFO-629PLF25TB	DFO-644PLF25TB
Water Absorption	<b>29 in (737 mm)</b>	<b>44 in (1118 mm)</b>	
	2 micron	AD-6292TB	AD-6442TB
	5 micron	AD-6295TB	AD-6445TB
	10 micron	AD-62910TB	AD-64410TB
	25 micron	AD-62925TB	AD-64425TB

### Accessories

Part Number	Description
101-G	Air Eliminator
115-C	Drain Valve
130-BT	Pressure Relief Valve 150#

Part Number	Description
120-Q	Differential Pressure Gauge
G-2105	Cover Gasket

# DVF16 Series

Vertical Filter Housings for use with DFO-6 and AD-6 Elements  
for Flows up to 704 gpm (2665 lpm)

## How to Order

Select the desired symbol (in the correct position) to construct a model code. Example:

BOX 1	BOX 2	BOX 3	BOX 4	BOX 5	BOX 6	BOX 7	BOX 8
DVF16	29	P	X	B	DP	A4	1

BOX 1: Filter Series	
Symbol	Description
<b>DVF16</b>	<b>Diesel Vertical Filter up to 704 gpm/2665 lpm</b>

BOX 4: Media Code	
Symbol	Description
<b>X</b>	<b>No Element Installed (1 required)<sup>1</sup></b>

BOX 7: Ports	
Symbol	Description
<b>A4</b>	<b>4" 150# RF ANSI</b>

BOX 2: Element Length	
Symbol	Description
<b>29</b>	<b>29 in (727 mm)</b>
<b>44</b>	<b>44 in (1118 mm)</b>

BOX 5: Seals	
Symbol	Description
<b>B</b>	<b>Nitrile</b>
V	Fluorocarbon

BOX 8: Options <sup>2</sup>	
Symbol	Description
<b>1</b>	<b>None</b>
AE	Air Eliminator
CL	Custom Leg Height <sup>3</sup>
DV	Drain Valve
PR	Pressure Relief Valve 150#

BOX 3: Filtration Type	
Symbol	Description
<b>P</b>	<b>Particulate</b>
<b>A</b>	<b>Water Absorption</b>

BOX 6: Pressure Gauge	
Symbol	Description
<b>P</b>	<b>Port Plugged</b>
<b>DP</b>	<b>Differential Pressure</b>
M2	Visual Automatic Reset

*Please note the bolded options reflect standard options with reduced lead-time.*

Notes:

1. Use the chosen codes from Box 2 and Box 3, along with the desired filtration rating to select the correct element from the tables below. **Example:** For model DVF16**29P**XBPA41, element DFO-629PLF10TB would be required.
2. Select one or more options, as desired.
3. Customer must supply the length for Dimension B referenced in Figure 2 on page 82.

## Replacement Elements

Type / Media		
<b>Particulate</b>	<b>29 in (737 mm)</b>	<b>44 in (1118 mm)</b>
2 micron	DFO-629PLF2TB	DFO-644PLF2TB
5 micron	DFO-629PLF5TB	DFO-644PLF5TB
10 micron	DFO-629PLF10TB	DFO-644PLF10TB
25 micron	DFO-629PLF25TB	DFO-644PLF25TB
<b>Water Absorption</b>	<b>29 in (737 mm)</b>	<b>44 in (1118 mm)</b>
2 micron	AD-6292TB	AD-6442TB
5 micron	AD-6295TB	AD-6445TB
10 micron	AD-62910TB	AD-64410TB
25 micron	AD-62925TB	AD-64425TB

## Accessories

Part Number	Description
101-G	Air Eliminator
115-C	Drain Valve
130-BT	Pressure Relief Valve 150#

Part Number	Description
120-Q	Differential Pressure Gauge
G-2033	Cover Gasket

# DVF20/24/28 Series

## Vertical Filter Housings for use with DFO-6 and AD-6 Elements

for Flows up to 2866 gpm (10174 lpm)

### How to Order

Select the desired symbol (in the correct position) to construct a model code. Example:

BOX 1	BOX 2	BOX 3	BOX 4	BOX 5	BOX 6	BOX 7	BOX 8
DVF20	44	P	X	B	DP	A6	1

BOX 1: Filter Series <sup>1</sup>	
Symbol	Description
DVF20	Diesel Vertical Filter up to 1056 gpm/3997 lpm
DVF24	Diesel Vertical Filter up to 1792 gpm/6783 lpm
DVF28	Diesel Vertical Filter up to 2866 gpm/10174 lpm

BOX 2: Element Length	
Symbol	Description
44	44 in (1118 mm)
56	56 in (1422 mm)

BOX 3: Filtration Type	
Symbol	Description
P	Particulate
A	Water Absorption

BOX 4: Media Code	
Symbol	Description
X	No Element Installed <sup>2,3</sup>

BOX 5: Seals	
Symbol	Description
B	Nitrile
V	Fluorocarbon

BOX 6: Indicator	
Symbol	Description
P	Port Plugged
DP	Differential Pressure
M2	Visual Automatic Reset

BOX 7: Ports	
Symbol	Description
A2	2" 150# RF ANSI
A3	3" 150# RF ANSI
A4	4" 150# RF ANSI
<b>A6</b>	<b>6" 150# RF ANSI</b>
<b>A8</b>	<b>8" 150# RF ANSI</b>

BOX 8: Options <sup>4</sup>	
Symbol	Description
<b>1</b>	<b>None</b>
AE	Air Eliminator
CL	Custom Leg Height <sup>5</sup>
DV	Drain Valve
PR	Pressure Relief Valve 150#

**Please note the bolded options reflect standard options with reduced lead-time.**

Notes:

- When DVF20 is selected in Box 1, select "44" in Box 2.
- Use the chosen codes from Box 2 and Box 3, along with the desired filtration rating to select the correct element from the tables below. **Example:** For model DVF20**44P**XBPA61, element DFO-644PLF10TB would be required.
- Element qty required: DVF20 (6), DVF24 (8), DVF28 (12)
- Select one or more options, as desired.
- Customer must supply the length for Dimension B referenced in Figure 2 on page 82.

### Replacement Elements

Type / Media			
Particulate	<b>44 in (1118 mm)</b>	<b>56 in (1422 mm)</b>	
	2 micron	DFO-644PLF2TB	DFO-656PLF2TB
	5 micron	DFO-644PLF5TB	DFO-656PLF5TB
	10 micron	DFO-644PLF10TB	DFO-656PLF10TB
	25 micron	DFO-644PLF25TB	DFO-656PLF25TB
Water Absorption	<b>44 in (1118 mm)</b>	<b>56 in (1422 mm)</b>	
	2 micron	AD-6442TB	AD-6562TB
	5 micron	AD-6445TB	AD-6565TB
	10 micron	AD-64410TB	AD-65610TB
	25 micron	AD-64425TB	AD-65625TB

### Accessories

Part Number	Description
101-G	Air Eliminator
115-C	Drain Valve
130-BT	Pressure Relief Valve 150#

Part Number	Description
120-Q	Differential Pressure Gauge
G-2027 (DVF20) G-2042 (DVF24) G-0769 (DVF28)	Cover Gasket

# DVF36 Series

## Vertical Filter Housings for use with DFO-6 and AD-6 Elements for Flows up to 4032 gpm (15261 lpm)

### How to Order

Select the desired symbol (in the correct position) to construct a model code. Example:

BOX 1	BOX 2	BOX 3	BOX 4	BOX 5	BOX 6	BOX 7	BOX 8
DVF36	44	P	X	B	DP	A10	1

BOX 1: Filter Series	
Symbol	Description
<b>DVF36</b>	<b>Diesel Vertical Filter up to 4032 gpm/15261 lpm</b>

BOX 4: Media Code	
Symbol	Description
<b>X</b>	<b>No Element Installed (18 required)<sup>1</sup></b>

BOX 7: Ports	
Symbol	Description
A6	6" 150# RF ANSI
A8	8" 150# RF ANSI
<b>A10</b>	<b>10" 150# RF ANSI</b>
A12	12" 150# RF ANSI

BOX 2: Element Length	
Symbol	Description
<b>44</b>	<b>44 in (1118 mm)</b>
56	56 in (1422 mm)

BOX 5: Seals	
Symbol	Description
<b>B</b>	<b>Nitrile</b>
V	Fluorocarbon

BOX 8: Options <sup>2</sup>	
Symbol	Description
<b>1</b>	<b>None</b>
AE	Air Eliminator
CL	Custom Leg Height <sup>3</sup>
DV	Drain Valve
PR	Pressure Relief Valve 150#

BOX 3: Filtration Type	
Symbol	Description
<b>P</b>	<b>Particulate</b>
<b>A</b>	<b>Water Absorption</b>

BOX 6: Indicator	
Symbol	Description
<b>P</b>	<b>Port Plugged</b>
<b>DP</b>	<b>Differential Pressure</b>
M2	Visual Automatic Reset

**Please note the bolded options reflect standard options with reduced lead-time.**

Notes:

1. Use the chosen codes from Box 2 and Box 3, along with the desired filtration rating to select the correct element from the tables below. **Example:** For model DVF36**44P**XBPA101, element DFO-644PLF10TB would be required.
2. Select one or more options, as desired.
3. Customer must supply the length for Dimension B referenced in Figure 2 on page 82.

### Replacement Elements

Type / Media		
<b>Particulate</b>	<b>44 in (1118 mm)</b>	<b>56 in (1422 mm)</b>
2 micron	DFO-644PLF2TB	DFO-656PLF2TB
5 micron	DFO-644PLF5TB	DFO-656PLF5TB
10 micron	DFO-644PLF10TB	DFO-656PLF10TB
25 micron	DFO-644PLF25TB	DFO-656PLF25TB
<b>Water Absorption</b>	<b>44 in (1118 mm)</b>	<b>56 in (1422 mm)</b>
2 micron	AD-6442TB	AD-6562TB
5 micron	AD-6445TB	AD-6565TB
10 micron	AD-64410TB	AD-65610TB
25 micron	AD-64425TB	AD-65625TB

### Accessories

Part Number	Description
101-G	Air Eliminator
115-C	Drain Valve
130-BT	Pressure Relief Valve 150#

Part Number	Description
120-Q	Differential Pressure Gauge
G-511A	Cover Gasket

# DVF42/48 Series

## Vertical Filter Housings for use with DFO-6 and AD-6 Elements

for Flows up to 7392 gpm (27979 lpm)

### How to Order

Select the desired symbol (in the correct position) to construct a model code. Example:

BOX 1	BOX 2	BOX 3	BOX 4	BOX 5	BOX 6	BOX 7	BOX 8
DVF42	44	P	X	B	DP	A10	1

BOX 1: Filter Series	
Symbol	Description
DVF42	Diesel Vertical Filter up to 6048 gpm/22892 lpm
DVF48	Diesel Vertical Filter up to 7392 gpm/27979 lpm

BOX 2: Element Length	
Symbol	Description
44	44 in (1118 mm)
56	56 in (1422 mm)

BOX 3: Filtration Type	
Symbol	Description
P	Particulate
A	Water Absorption

BOX 4: Media Code	
Symbol	Description
X	No Element Installed <sup>2,3</sup>

BOX 5: Seals	
Symbol	Description
B	Nitrile
V	Fluorocarbon

BOX 6: Indicator	
Symbol	Description
P	Port Plugged
DP	Differential Pressure
M2	Visual Automatic Reset

BOX 7: Ports	
Symbol	Description
A6	6" 150# RF ANSI
A8	8" 150# RF ANSI
<b>A10</b>	<b>10" 150# RF ANSI</b>
<b>A12</b>	<b>12" 150# RF ANSI</b>

BOX 8: Options <sup>1</sup>	
Symbol	Description
<b>1</b>	<b>None</b>
AE	Air Eliminator
CL	Custom Leg Height
DV	Drain Valve
PR	Pressure Relief Valve 150#

**Please note the bolded options reflect standard options with reduced lead-time.**

Notes:

- When DVF48 is selected in Box 1, select "56" in Box 2.
- Use the chosen codes from Box 2 and Box 3, along with the desired filtration rating to select the correct element from the tables below. **Example:** For model DVF42**44P**XBPA101, element DFO-644PLF10TB would be required.
- Element qty required: DVF42 (27), DVF48 (33)
- Select one or more options, as desired.
- Customer must supply the length for Dimension B referenced in Figure 2 on page 82.

### Replacement Elements

Type / Media		
<b>Particulate</b>	<b>44 in (1118 mm)</b>	<b>56 in (1422 mm)</b>
2 micron	DFO-644PLF2TB	DFO-656PLF2TB
5 micron	DFO-644PLF5TB	DFO-656PLF5TB
10 micron	DFO-644PLF10TB	DFO-656PLF10TB
25 micron	DFO-644PLF25TB	DFO-656PLF25TB
<b>Water Absorption</b>	<b>44 in (1118 mm)</b>	<b>56 in (1422 mm)</b>
2 micron	AD-6442TB	AD-6562TB
5 micron	AD-6445TB	AD-6565TB
10 micron	AD-64410TB	AD-65610TB
25 micron	AD-64425TB	AD-65625TB

### Accessories

Part Number	Description
101-G	Air Eliminator
115-C	Drain Valve
130-BT	Pressure Relief Valve 150#

Part Number	Description
120-Q	Differential Pressure Gauge
G-0050E (DVF42) N/A (DVF48)	Cover Gasket

# DV Series

## Vertical Filter-Coalescer/Separator Housings for use with DI-6 and DS0-6 Elements

Dry fuel is more important than ever with HPCR (High Pressure Common Rail) systems becoming the standard in diesel engines. Water can displace fuel in the injectors and high pressure fuel pumps causing a lack of lubricity, thus resulting in premature wear. This wear can cause a loss of fuel economy, a less efficient engine, down time, component failure, catastrophic engine failure and potentially the rejection of a warranty claim from engine manufacture. Engine manufactures are requiring standard diesel, D975, to be less than 100 parts per million water. Current requirements for water per D975 is less than 500 parts per million water. All bulk fuel could potentially not meet OEM requirements while still meeting D975 specifications. The DV series can coalesce water from diesel fuel in flows from 330 gallons per minute to 2,100 gallons per minute in a standard single vessel. The DV series from Parker can easily achieve OEM requirements for water in parts per million.

### Typical Applications

The DV series offer many options which makes the product perfect for many markets and applications. In the Natural Resources market, the DV can be utilized in mining equipment, fuel transfer, fuel polishing and fuel delivery for coalescing water. Opportunities exist for small and large fuel terminals. The Power Generation market offers several potential applications. Fuel transfers from terminals and polishing of bulk storage tanks, the DV can provide superior dry fuel. The Transportation market also provides many different opportunities. Larger commercial marine vessels can coalesce water as it is offloaded from land or sea suppliers. Railroad terminals can coalesce water from fuel as it is transferred to maintain superior fuel quality. The DV series can be used to meet the water specifications in parts per million as required by the engine manufactures. Clean Dry fuel allows the engines to operate at maximum efficiencies and maintain emission requirements.



# DV Series

## Features

### Standard Design Features

- 1 150 psi welded steel ASME Code construction (stamp on request)
- 2 Epoxy-coated interior, primed exterior
- 3 Swing bolt closure with O-ring seal
- 4 Inlet/Outlet sample ports
- 5 RF flanged connections
- 6 Threaded base coalescer
- 7 Carbon steel construct
- 8 Hydraulic lifting davit

### Options

- 9 Automatic air vent
- 10 Pressure relief valve
- 11 Differential pressure gauge
- 12 Water interface control
- 13 Water sight glass
- 14 Sampling probes
- 15 Manual drain valve
- 16 Water slug valve
- 17 Sump heater
- 18 Choice of micron rating from 5 to 25 microns
- 19 Choice of pleated or depth type media

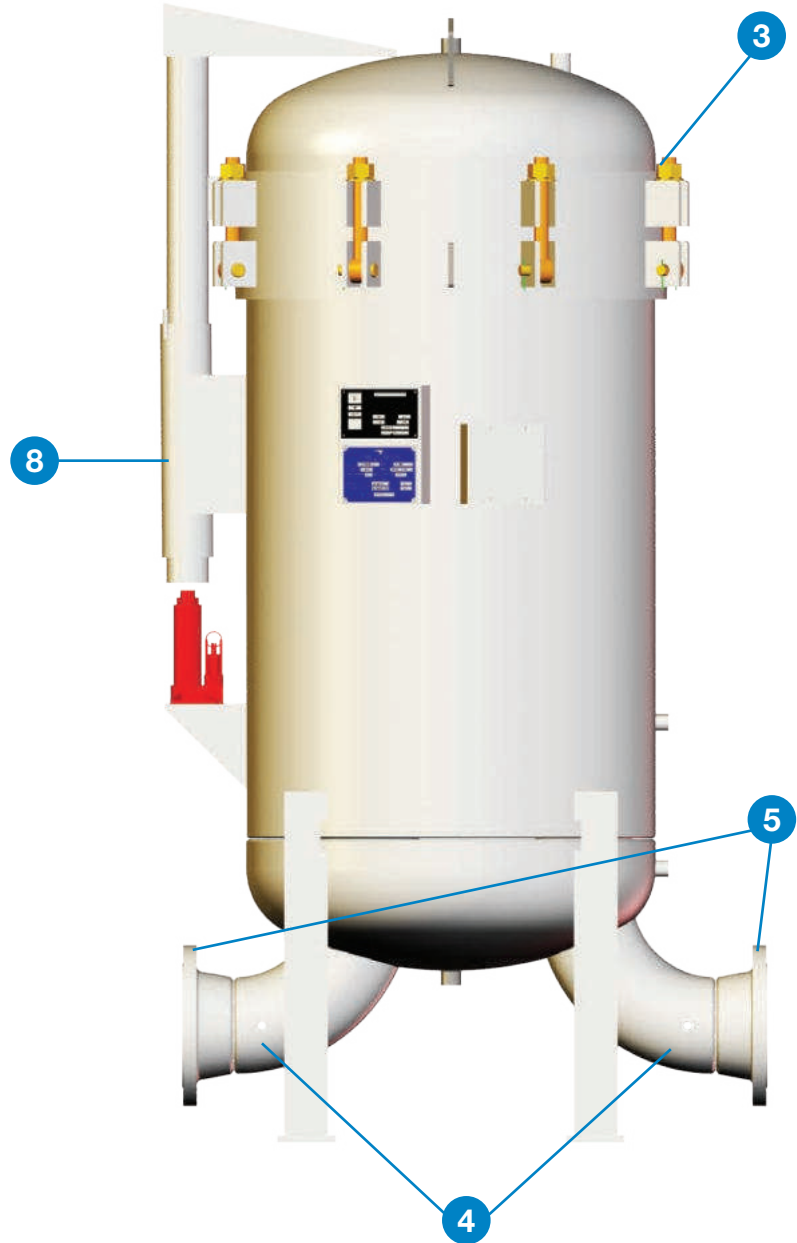

# DV Series Specifications

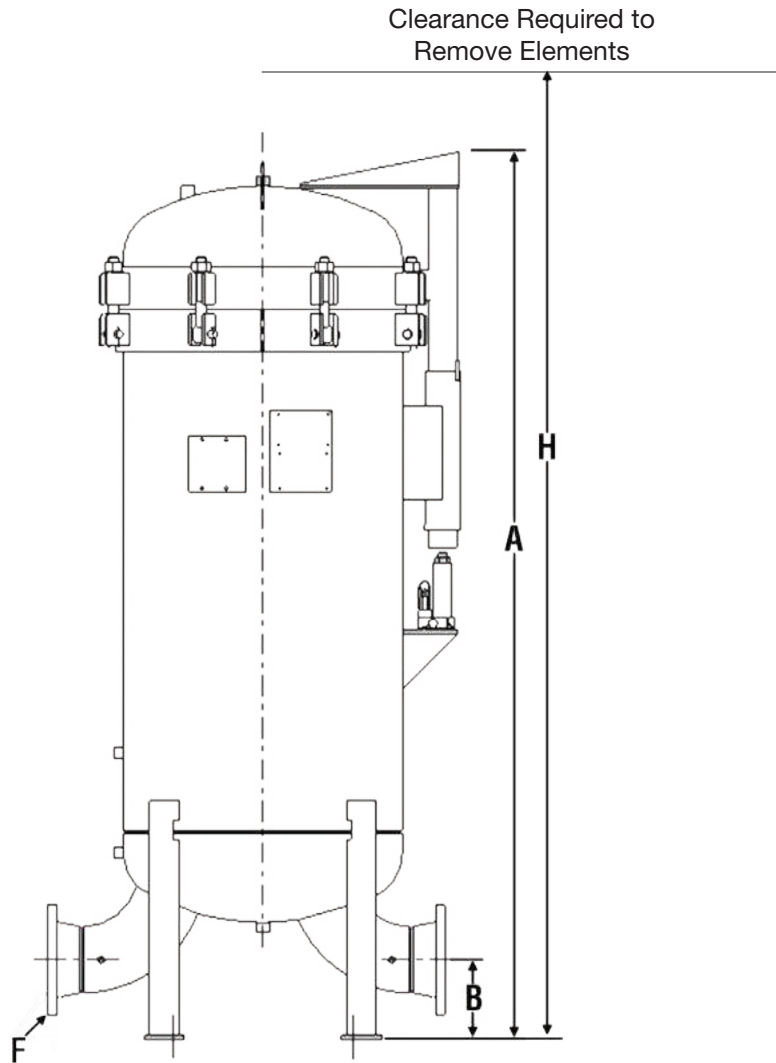

Figure 1

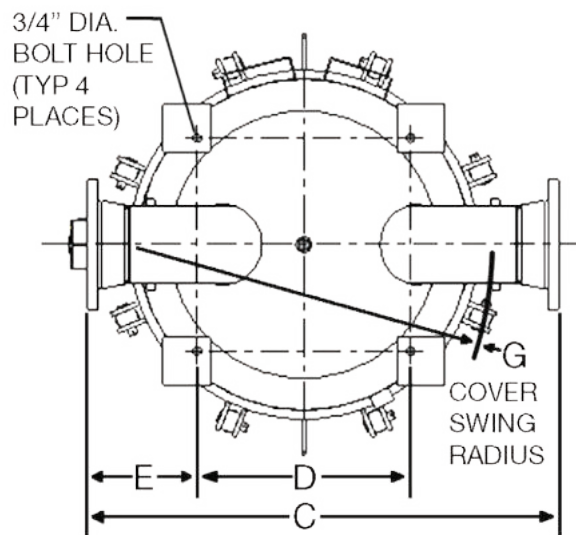

Figure 2

# DV Series

## Specifications

Model Number	Flow Rate Range gpm (lpm)		Elements		Dimensions in (mm)		
	Max	Target	DI DSO	Qty of Elements	A	B	C
DV2222	220 (835)	130 (500)	DI-622 DSO-622	4 3	62 (131)	8 (203)	27.13 (203)
DV2233	330 (1250)	200 (750)	DI-633 DSO-629	4 3	69 (198)	8 (203)	27.13 (203)
DV2833	495 (1875)	300 (1125)	DI-633 DSO-629	6 5	83 (522)	8 (203)	40 (203)
DV2844	660 (2500)	400 (1500)	DI-644 DSO-633	6 5	89 (792)	8 (203)	40 (203)
DV3638	1045 (3955)	630 (2380)	DI-638 DSO-629	11 9	91.56 (1188)	8 (203)	63.25 (203)
DV3644	1210 (4580)	730 (2750)	DI-644 DSO-633	11 9	96.38 (1584)	9 (229)	52.13 (229)
DV3656	1540 (5830)	930 (3500)	DI-656 DSO-644	11 9	109.69 (2016)	9 (229)	52.13 (229)
DV4244	1650 (6245)	995 (3750)	DI-644 DSO-633	15 12	103.38 (2379)	9 (229)	55.31 (229)
DV4256	2100 (7950)	1260 (4770)	DI-656 DSO-644	15 12	119.13 (2379)	9 (229)	55.31 (229)

Model Number	Dimensions in (mm)					Wt. w/ Skid lbs (kgs)	Volume US gal (L)
	D	E	F	G	H		
DV2222	15.5 (394)	6.25 (159)	4 (102)	30 (762)	86 (2184)	1110 (503)	64 (242)
DV2233	15.5 (394)	6.25 (159)	4 (102)	30 (762)	102 (2591)	1130 (513)	72 (273)
DV2833	18 (457)	12.63 (321)	6 (152)	35 (889)	118 (2997)	1650 (748)	170 (644)
DV2844	18 (457)	12.63 (321)	6 (152)	35 (889)	133 (3378)	1690 (767)	185 (700)
DV3638	23 (584)	20.13 (511)	6 (152)	44 (1118)	129 (3277)	2080 (943)	280 (1060)
DV3644	23 (584)	14.63 (371)	8 (203)	44 (1118)	140 (3556)	2150 (975)	305 (1155)
DV3656	23 (584)	14.63 (371)	8 (203)	44 (1118)	160 (4064)	2300 (1043)	355 (1344)
DV4244	28 (711)	15 (381)	8 (203)	50 (1270)	150 (3810)	3350 (1520)	450 (1703)
DV4256	28 (711)	15 (381)	8 (203)	50 (1270)	165 (4191)	3500 (1588)	520 (1968)

## Element Coalescing Performance

>99% efficient at rated flows

*Dimensions shown are for estimating purposes only. For exact dimensional detail, obtain certified copy of vessel drawing.  
\*Flow rates provided are for illustrative purposes. Actual flow rates may vary based on field conditions.*

# DV22 Series

## Vertical Filter-Coalescer/Separator Housings

### for use with DI-6 and DSO-6 Elements

for Flows up to 330 gpm (1250 lpm)

## How to Order

Select the desired symbol (in the correct position) to construct a model code. Example:

BOX 1	BOX 2	BOX 3	BOX 4	BOX 5	BOX 6	BOX 7	BOX 8
DV22	22	CS	X	B	DP	A4	1

BOX 1: Filter Series	
Symbol	Description
<b>DV22</b>	<b>Diesel Vertical Filter Coalescer/Separator up to 330 gpm/1250 lpm</b>

BOX 2: Element Length	
Symbol	Description
<b>22</b>	<b>22 in (559 mm)</b>
<b>33</b>	<b>33 in (838 mm)</b>

BOX 3: Filtration Type	
Symbol	Description
<b>CS</b>	<b>Coalescer/Separator</b>

BOX 4: Media Code	
Symbol	Description
<b>X</b>	<b>No Element Installed<sup>1,2</sup></b>

BOX 5: Seals	
Symbol	Description
<b>B</b>	<b>Nitrile</b>
V	Fluorocarbon

BOX 6: Indicator	
Symbol	Description
<b>P</b>	<b>Port Plugged</b>
<b>DP</b>	<b>Differential Pressure</b>

BOX 7: Ports	
Symbol	Description
A2	2" 150# RF ANSI
A3	3" 150# RF ANSI
<b>A4</b>	<b>4" 150# RF ANSI</b>

BOX 8: Options <sup>3</sup>	
Symbol	Description
<b>1</b>	<b>None</b>
AE	Air Eliminator
CL	Custom Leg Height <sup>4</sup>
DV	Drain Valve
PR	Pressure Relief Valve 150#
SG	Sight Glass

*Please note the bolded options reflect standard options with reduced lead-time.*

Notes:

- Use the code chosen from Box 2 along with the desired filtration rating and separator material to select the correct element from the table below. **Example:** For model DV22**22**CSXBPA41 with 10 micron coalescer and cellulose separator, DI-622D10TB and element DSO-622PLF3 would be required.
- Element qty required: (4) Coalescer, (3) Separator
- Select one or more options, as desired.
- Customer must supply the length for Dimension B referenced in Figure 1 on page 94.

## Replacement Elements

Type / Media		22 in (559 mm)	22 in (559 mm)	33 in (838 mm)	29 in (737 mm)
Coalescer	Separator				
5 micron	Cellulose (PL) Screen (C)	DI-622D5TB	DSO-622PLF3 DSO-622C	DI-633D5TB	DSO-629PLF3 DSO-629C
10 micron		DI-622D10TB		DI-633D10TB	
25 micron		DI-622D25TB		DI-633D25TB	

## Accessories

Part Number	Description
101-G	Air Eliminator
115-C	Drain Valve
130-BT	Pressure Relief Valve 150#

Part Number	Description
120-Q	Differential Pressure Gauge
138-P	Sight Glass
G-2042	Cover Gasket

# DV28 Series

## Vertical Filter-Coalescer/Separator Housings

### for use with DI-6 and DSO-6 Elements

for Flows up to 660 gpm (2500 lpm)

## How to Order

Select the desired symbol (in the correct position) to construct a model code. Example:

BOX 1	BOX 2	BOX 3	BOX 4	BOX 5	BOX 6	BOX 7	BOX 8
DV28	33	CS	X	B	DP	A6	1

BOX 1: Filter Series	
Symbol	Description
<b>DV28</b>	<b>Diesel Vertical Filter Coalescer/Separator up to 660 gpm/2500 lpm</b>

BOX 2: Element Length	
Symbol	Description
<b>33</b>	<b>33 in (838 mm)</b>
44	44 in (1118 mm)

BOX 3: Filtration Type	
Symbol	Description
<b>CS</b>	<b>Coalescer/Separator</b>

BOX 4: Media Code	
Symbol	Description
<b>X</b>	<b>No Element Installed<sup>1,2</sup></b>

BOX 5: Seals	
Symbol	Description
<b>B</b>	<b>Nitrile</b>
V	Fluorocarbon

BOX 6: Indicator	
Symbol	Description
<b>P</b>	<b>Port Plugged</b>
<b>DP</b>	<b>Differential Pressure</b>

BOX 7: Ports	
Symbol	Description
A3	3" 150# RF ANSI
A4	4" 150# RF ANSI
<b>A6</b>	<b>6" 150# RF ANSI</b>

BOX 8: Options <sup>3</sup>	
Symbol	Description
<b>1</b>	<b>None</b>
AE	Air Eliminator
CL	Custom Leg Height <sup>4</sup>
DV	Drain Valve
PR	Pressure Relief Valve 150#
SG	Sight Glass

*Please note the bolded options reflect standard options with reduced lead-time.*

Notes:

- Use the code chosen from Box 2 along with the desired filtration rating and separator material to select the correct element from the table below. **Example:** For model DV28**33**CSXBPA61 with 10 micron coalescer and cellulose separator, DI-633D10TB and element DSO-629PLF3 would be required.
- Element qty required: (6) Coalescer, (5) Sparator
- Select one or more options, as desired.
- Customer must supply the length for Dimension B referenced in Figure 1 on page 94.

## Replacement Elements

Type / Media		33 in (838 mm)	29 in (737 mm)	44 in (1118 mm)	33 in (838 mm)
Coalescer	Separator				
5 micron	Cellulose (PL) Screen (C)	DI-633D5TB	DSO-629PLF3 DSO-629C	DI-644D5TB	DSO-633PLF3 DSO-633C
10 micron		DI-633D10TB		DI-644D10TB	
25 micron		DI-633D25TB		DI-644D25TB	

## Accessories

Part Number	Description
101-G	Air Eliminator
115-C	Drain Valve
130-BT	Pressure Relief Valve 150#

Part Number	Description
120-Q	Differential Pressure Gauge
138-P	Sight Glass
G-0769	Cover Gasket

# DV36 Series

## Vertical Filter-Coalescer/Separator Housings

### for use with DI-6 and DSO-6 Elements

for Flows up to 1540 gpm (5830 lpm)

## How to Order

Select the desired symbol (in the correct position) to construct a model code. Example:

BOX 1	BOX 2	BOX 3	BOX 4	BOX 5	BOX 6	BOX 7	BOX 8
DV36	38	CS	X	B	DP	A8	1

BOX 1: Filter Series	
Symbol	Description
<b>DV36</b>	<b>Diesel Vertical Filter Coalescer/Separator up to 1540 gpm/5830 lpm</b>

BOX 2: Element Length	
Symbol	Description
<b>38</b>	<b>38 in (965 mm)</b>
44	44 in (1118 mm)
56	56 in (1422 mm)

BOX 3: Filtration Type	
Symbol	Description
<b>CS</b>	<b>Coalescer/Separator</b>

BOX 4: Media Code	
Symbol	Description
<b>X</b>	<b>No Element Installed<sup>1,2</sup></b>

BOX 5: Seals	
Symbol	Description
<b>B</b>	<b>Nitrile</b>
V	Fluorocarbon

BOX 6: Indicator	
Symbol	Description
<b>P</b>	<b>Port Plugged</b>
<b>DP</b>	<b>Differential Pressure</b>

BOX 7: Ports	
Symbol	Description
A4	4" 150# RF ANSI
A6	6" 150# RF ANSI
<b>A8</b>	<b>8" 150# RF ANSI</b>

BOX 8: Options <sup>3</sup>	
Symbol	Description
<b>1</b>	<b>None</b>
AE	Air Eliminator
CL	Custom Leg Height <sup>4</sup>
DV	Drain Valve
PR	Pressure Relief Valve 150#
SG	Sight Glass

*Please note the bolded options reflect standard options with reduced lead-time.*

Notes:

1. Use the code chosen from Box 2 along with the desired filtration rating and separator material to select the correct element from the table below. **Example:** For model DV36**44**CSXBPA81 with 10 micron coalescer and cellulose separator, DI-644D10TB and element DSO-633PLF3 would be required.
2. Element qty required: (11) Coalescer, (9) Separator
3. Select one or more options, as desired.
4. Customer must supply the length for Dimension B referenced in Figure 1 on page 94.

## Replacement Elements

Type / Media		38in (965 mm)		29 in (737 mm)		44 in (1118 mm)		33 in (838 mm)		56 in (1422 mm)		44 in (1118 mm)	
Coalescer	Separator												
5 micron	Cellulose (PL) Screen (C)	DI-638D5TB	DSO-629PLF3 DSO-629C	DI-644D5TB	DSO-633PLF3 DSO-633C	DI-656D5TB	DSO-644PLF3 DSO-644C	DI-638D10TB	DI-644D10TB	DI-656D10TB	DI-638D25TB	DI-644D25TB	DI-656D25TB
10 micron													
25 micron													

## Accessories

Part Number	Description
101-G	Air Eliminator
115-C	Drain Valve
130-BT	Pressure Relief Valve 150#

Part Number	Description
120-Q	Differential Pressure Gauge
138-P	Sight Glass
G-0511A	Cover Gasket

# DV42 Series

## Vertical Filter-Coalescer/Separator Housings

### for use with DI-6 and DSO-6 Elements

for Flows up to 2100 gpm (7950 lpm)

## How to Order

Select the desired symbol (in the correct position) to construct a model code. Example:

BOX 1	BOX 2	BOX 3	BOX 4	BOX 5	BOX 6	BOX 7	BOX 8
DV42	44	CS	X	B	DP	A8	1

BOX 1: Filter Series	
Symbol	Description
<b>DV42</b>	<b>Diesel Vertical Filter Coalescer/Separator up to 2100 gpm/7950 lpm</b>

BOX 2: Element Length	
Symbol	Description
<b>44</b>	<b>44 in (1118 mm)</b>
56	56 in (1422 mm)

BOX 3: Filtration Type	
Symbol	Description
<b>CS</b>	<b>Coalescer/Separator</b>

BOX 4: Media Code	
Symbol	Description
<b>X</b>	<b>No Element Installed<sup>1,2</sup></b>

BOX 5: Seals	
Symbol	Description
<b>B</b>	<b>Nitrile</b>
V	Fluorocarbon

BOX 6: Indicator	
Symbol	Description
<b>P</b>	<b>Port Plugged</b>
<b>DP</b>	<b>Differential Pressure</b>

BOX 7: Ports	
Symbol	Description
A6	6" 150# RF ANSI
<b>A8</b>	<b>8" 150# RF ANSI</b>
A10	10" 150# RF ANSI

BOX 8: Options <sup>3</sup>	
Symbol	Description
<b>1</b>	<b>None</b>
AE	Air Eliminator
CL	Custom Leg Height <sup>4</sup>
DV	Drain Valve
PR	Pressure Relief Valve 150#
SG	Sight Glass

*Please note the bolded options reflect standard options with reduced lead-time.*

Notes:

- Use the code chosen from Box 2 along with the desired filtration rating and separator material to select the correct element from the table below. **Example:** For model DV42**44**CSXBPA81 with 10 micron coalescer and cellulose separator, DI-644D10TB and element DSO-633PLF3 would be required.
- Element qty required: (15) Coalescer, (12) Separator
- Select one or more options, as desired.
- Customer must supply the length for Dimension B referenced in Figure 1 on page 94.

## Replacement Elements

Type / Media		44 in (1118 mm)	33 in (838 mm)	56 in (1422 mm)	44 in (1118 mm)
Coalescer	Separator				
5 micron	Cellulose (PL)	DI-644D5TB	DSO-633PLF3	DI-656D5TB	DSO-644PLF3
10 micron		DI-644D10TB		DI-656D10TB	
25 micron	Screen (C)	DI-644D25TB	DSO-633C	DI-656D25TB	DSO-644C

## Accessories

Part Number	Description
101-G	Air Eliminator
115-C	Drain Valve
130-BT	Pressure Relief Valve 150#

Part Number	Description
120-Q	Differential Pressure Gauge
138-P	Sight Glass
G-0050E	Cover Gasket

# Diesel Filtration Skid

## DFS™ Series - System for Removal of Particulates and Protection from Water Contaminants

Providing high quality fuel to the modern high pressure common rail fuel injection systems is imperative to avoid costly downtime and engine repair.

The Parker Diesel Filtration Skid (DFS) plays an important role in a comprehensive fuel contaminant control program as it provides fuel conditioning to assure the consistent removal of abrasive particles and damaging water.

The DFS offers a complete fuel filtration solution which incorporates both particulate and water contaminant removal technologies mounted on a skid base that can be quickly installed and put into operation.

Key components of the DFS includes a particulate housing (DVF) and a coalescing (DV) housing which have proven to withstand years of service in the most challenging environments. Parker DFO particulate filters and DI and DSO coalescer and separator elements are used for conditioning contaminated fuels to meet the most stringent ISO 4406 and ASTM D975 standards for emulsified and free water as well as abrasive particulate. All filtration elements are available with threaded base endcap option for quick filter removal and ease of installation.



# Diesel Filtration Skid

## Features

### Standard Design Features

- 1 ASME code epoxy painted carbon steel vessels (stamp on request)
- 2 Epoxy-coated interior
- 3 Swing bolt closure with nitrile cover seals
- 4 Independent differential pressure gauges
- 5 Air eliminators
- 6 Walkway
- 7 Inlet/Outlet sample ports
- 8 Hydraulic lifting davit<sup>1</sup>
- 9 Isolation valves
- 10 Pressure relief valve
- 11 Threaded base coalescer
- 12 Support hand rail
- 13 Water sight glass

### Options

- 14 Electronic water sensing
- 15 Fuel Condition Monitoring

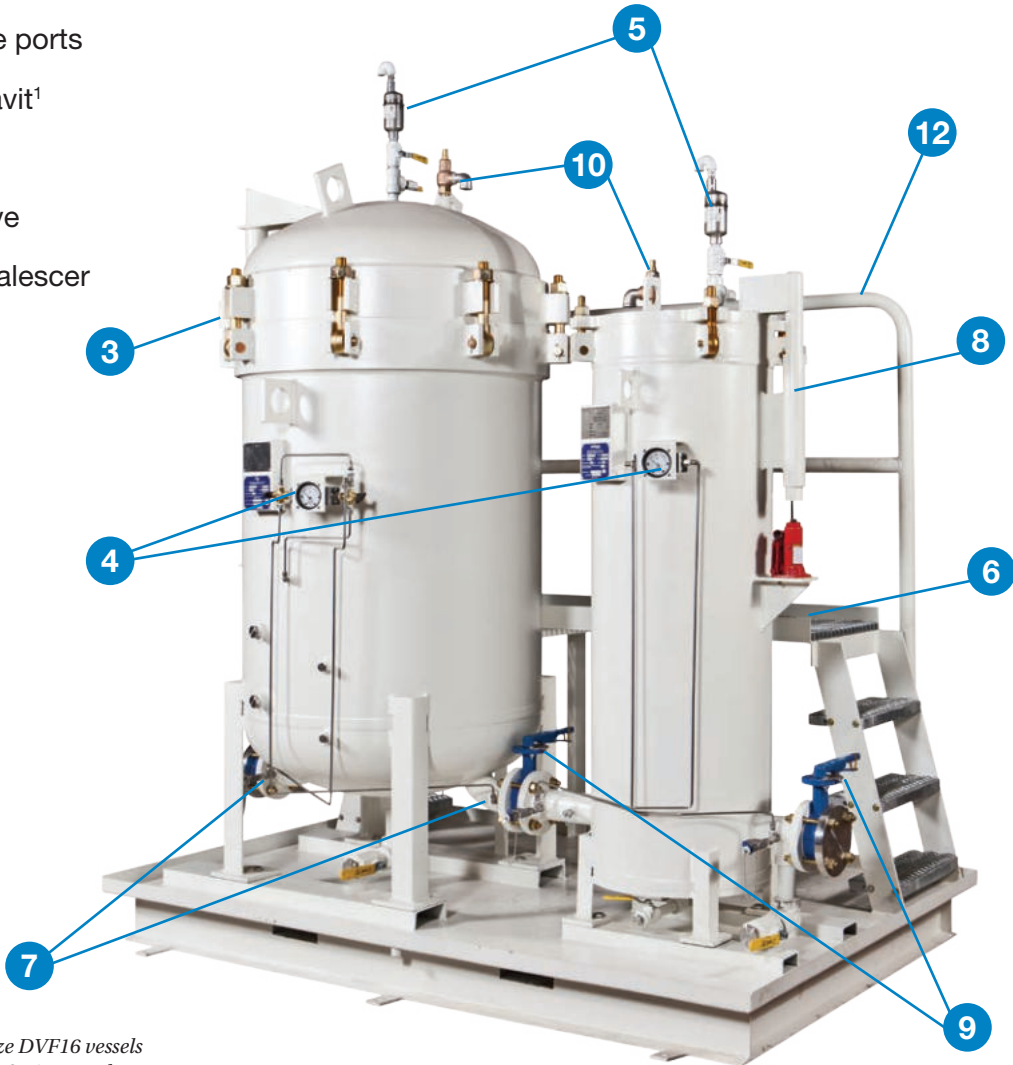

1. DFS1 and DFS2 system utilize DVF16 vessels that have flat covers. DVF16 Series vessels do not have hydraulic lift jacks.

# Diesel Filtration Skid

## Features & Specifications

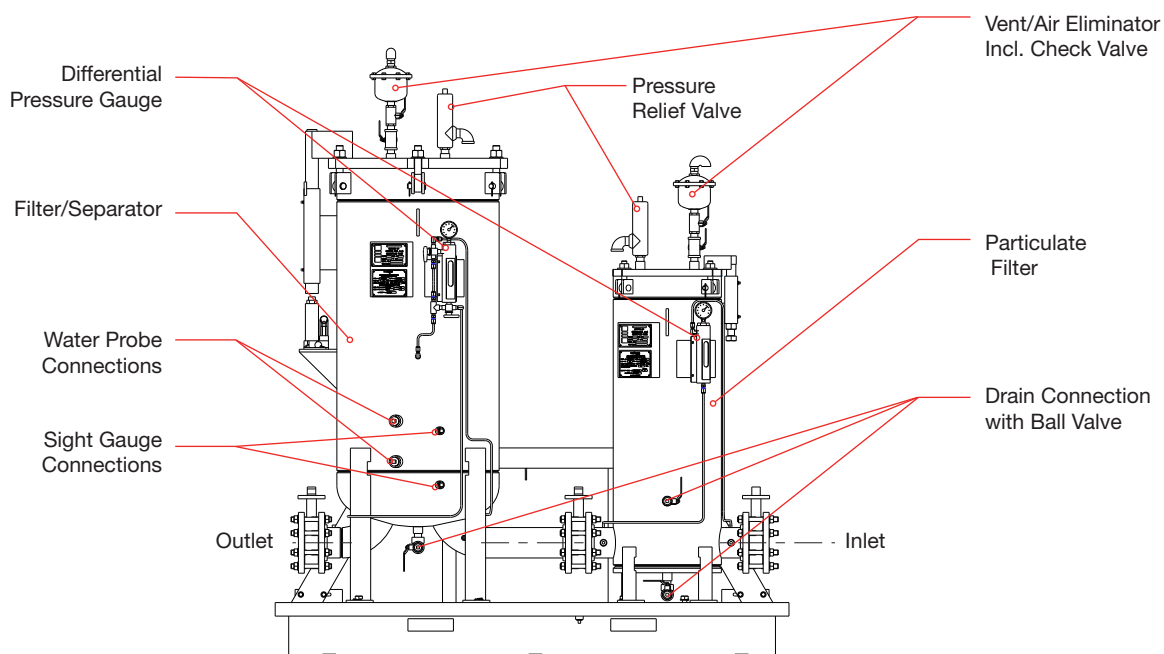

### Specifications

Parker recommends use of threaded base endcaps for ease of installation and to minimize components.

Series	Flow Rate*		Filter Housing	Elements		Coalescer Housing	Coalescers		Separators		Approximate Footprint mm (in)	Approx. DryWeight (w/o Elements, Tie Rods, Spider Plate) lb (kg)	I/O Flange in (mm)
	Maximum gpm (lpm)	Target gpm (lpm)		Qty of Elements	Element Part Number		Qty of Elements	Element Part Number	Qty of Elements	Element Part Number			
DFS1	330 (1250)	200 (750)	DVF1629	4	DFO-629	DV2233	4	DI-633	3	DSO-629	70 x 60 (1778 x 1524)	1985 (900)	4 (102)
DFS2	570 (2160)	345 (1300)	DVF1644	4	DFO-644	DV2838	6	DI-638	5	DSO-629	80 x 60 (2032 x 1524)	2250 (1021)	4 (102)
DFS3	1045 (3955)	630 (2380)	DVF2044	6	DFO-644	DV3638	11	DI-638	9	DSO-629	110 x 80 (2794 x 2032)	3400 (1542)	6 (152)

Dimensions shown are for estimating purposes only. For exact dimensional detail, obtain certified copy of vessel drawing.  
 \*Flow rates provided are for illustrative purposes. Actual flow rates may vary based on field conditions.

# Diesel Filtration Skid

## DFS™ Series - System for Removal of Particulates and Protection from Water Contaminants

### How to Order

Select the desired symbol (in the correct position) to construct a model code. Example:

BOX 1	BOX 2	BOX 3	BOX 4	BOX 5	BOX 6	BOX 7	BOX 8
DFS	1	PCS	X	B	DP	A4	1

BOX 1: Filter Series	
Symbol	Description
<b>DFS</b>	<b>Diesel Fuel Skid System</b>

BOX 2: Size <sup>1,2</sup>	
Symbol	Description
<b>1</b>	<b>Max 330 gpm (1250 lpm)</b>
<b>2</b>	<b>Max 570 gpm (2160 lpm)</b>
<b>3</b>	<b>Max 1045 gpm (3955 lpm)</b>

BOX 3: Particulate Media Code	
Symbol	Description
<b>PCS</b>	<b>Particulate/Coalescer/Separator</b>

BOX 4: Coalescer Media Code	
Symbol	Description
<b>X</b>	<b>No Element Installed<sup>3</sup></b>

\*Note: Always choose equal to or greater than particulate media code

BOX 5: Seals	
Symbol	Description
<b>B</b>	<b>Nitrile</b>
V	Fluorocarbon

BOX 6: Indicator	
Symbol	Description
<b>DP</b>	<b>Differential Pressure</b>

BOX 7: Ports	
Symbol	Description
<b>A4</b>	<b>4" 150# RF ANSI Flange</b>
<b>A6</b>	<b>6" 150# RF ANSI Flange</b>

BOX 8: Options <sup>4</sup>	
Symbol	Description
<b>1</b>	<b>None</b>
EWS	Electronic Water Sensing
IPM	Integrated Particulate Monitor (IPM-210)

*Please note the bolded options reflect standard options with reduced lead-time.*

#### Notes:

1. If choosing "1" or "2" in Box 2, select "B4" in Box 7.
2. If choosing "3" in Box 2, select "B6" in Box 7.
3. Use the chosen codes from Box 2 and Box 3, select the element numbers that match the desired filtration rating and the desired separator material. **Example:** For model DFS1**PCS**XBDPA61 with 10 micron particulate and coalescer, cellulose separator, DFO-629PLF10TB, DI-633D10TB and DSO-629PLF3 would be required.
4. Select one or more options, as desired.

### Replacement Elements

Type / Media		DFS1		DFS2		DFS3	
<b>Particulate</b>							
2 micron		DFO-629PLF2TB		DFO-644PLF2TB		DFO-644PLF2TB	
5 micron		DFO-629PLF5TB		DFO-644PLF5TB		DFO-644PLF5TB	
10 micron		DFO-629PLF10TB		DFO-644PLF10TB		DFO-644PLF10TB	
25 micron		DFO-629PLF25TB		DFO-644PLF25TB		DFO-644PLF25TB	
<b>Coalescer</b>	<b>Separator</b>	<b>DFS1</b>		<b>DFS2</b>		<b>DFS3</b>	
5 micron	Cellulose (PL) Screen (C)	DI-633D5TB	DSO-629PLF3	DI-638D5TB	DSO-629PLF3	DI-638D5TB	DSO-629PLF3
10 micron		DI-633D10TB		DI-638D10TB		DI-638D10TB	
25 micron		DI-633D25TB		DI-638D25TB		DI-638D25TB	
			DSO-629C		DSO-629C		DSO-629C

### Accessories

Description	Part Number		
	DFS1	DFS2	DFS3
Differential Pressure Gauge	120-Q	120-Q	120-Q
Coalescer/Separator Cover Gasket	G-2042	G-0769	G-0511A
Particulate Cover Gasket	G-2033	G-2033	G-2027



# Appendix

## Laboratory

### Analytical Laboratory

The HFFD Analytical Laboratory houses a wide range of capabilities to support the development of filtration products. These capabilities include the testing of filters, in-house quality control testing, and the analysis of customer-provided samples. Using our broad range of cutting edge technology and diagnostic equipment for conducting both quantitative and qualitative testing, Velcon is committed to providing quality solutions and industry leading technology. All equipment and testing are performed within the guidelines of ASTM, ISO, SAE, and ANSI standards.

- **30 keV SEM Scanning Electron Microscope (SEM) with Energy Dispersive X-Ray Spectroscopy (EDS)**
- **Fourier Transform Infrared (FT-IR) Spectrometer**
- **Porometer**
- **Particle Counter and Automatic Bottle Sampler**
- **Karl Fischer Titration**
- **Interfacial Tensiometer (IFT)**
- **Micro-Separometer**
- **Ultraviolet (UV) Spectrophotometer**
- **Microscope Station**
- **Viscosity & pH Balance Station**
- **Analytical Balances**

### Diesel Fuel Laboratory

Parker HFFD is committed to supplying the highest quality filtration technology available. Our state-of-the-art Diesel Fuel Laboratory is uniquely capable of performing full-flow single-pass efficiency testing similar to real world conditions. We also structurally challenge our products to assure consistent performance in the most extreme conditions. At Parker HFFD, we stand behind our products, as we continue to seek solutions to ensure quality fuel whenever and wherever needed.

### Testing Capabilities

#### Fuel

Ultra Low Sulfur Diesel (ULSD) red dyed; All tests can be performed with various blend concentrations of biodiesel

#### Resistance-to-flow Test

Flow rates up to 60 US gpm.

Typical product testing from 20% to 120% of rated flow

#### Retention Test

ISO codes - through influent and effluent particle counts  
Efficiency (single pass); Beta ratios

#### Solids Capacity Test

Contamination loading conducted to maximum rated differential pressure

#### Collapse Test

Maximum product differential pressure to component and product failure; Assures structural integrity beyond element solids capacity

#### Media Migration Test

Effluent filtration media migration test to assure product cleanliness

#### Solids and Water Test - Environmental Conditions

Retention testing in single pass mode with a slurry combination of both solids and water; Element capacity is measured at terminal pressure

#### Spin-on Seal Test

Maximum product seal pressure  
**Emulsified Water Coalescing Test**  
Water injected before system pump; Testing to assure a product affectivity to remove emulsified water from diesel fluids

#### Coarse Water Coalescing Test

Water injected after system pump  
Testing to assure a product affectivity to remove bulk water from diesel fluids

### Laboratory Services

- **Custom product testing available for specialty application needs**
- **Fluid filtration analysis to determine optimal product application**
- **Post use contamination analysis to determine level and composition of contaminants**
- **Customized laboratory reports for informed decision making**



# Appendix

## Interpreting Data

### Element Efficiency

To determine element efficiency, Parker uses data from SAE J1985 for each media grade. The data is plotted as the beta ratio vs micron size for each media grade available. This allows for each determination of the beta ratio at different particle sizes. To read the chart correctly simply follow a few quick steps.

To determine beta ratio/efficiency at a particular particle size:

1. Choose micron size from horizontal axis.
2. Follow line upward until it intersects the media grade of interest.
3. For the beta ratio, draw a horizontal line until it intersects the left vertical axis and record the number.
4. For the efficiency, draw a horizontal line until it intersects the right vertical axis and record the number.

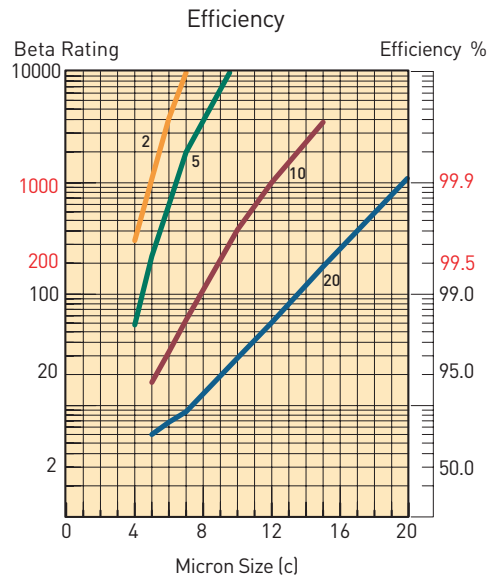

### Element Capacity

To estimate element life, Parker uses data from SAE J905 for each media grade and configuration available. The data is plotted as the differential pressure vs capacity plot to allow for best comparisons between different indicator/bypass settings and also other manufacturers. SAE J905 specifies the fluid type and contaminant type and Parker determines the best flow rate for the element configuration to optimize element life. The specifier can then estimate the life of the element by choosing the changeout pressure. It is only an estimate because the actual life of the element in its intended application depends on several variables:

- Viscosity
- Flow rate
- Contaminant Type
- Changeout pressure

To estimate the element life, the specifier can determine what indicator setting will be used to signal service is required. If no indicator is used, then use the bypass value for the specified filter. To read the charts properly, follow the few quick steps below.

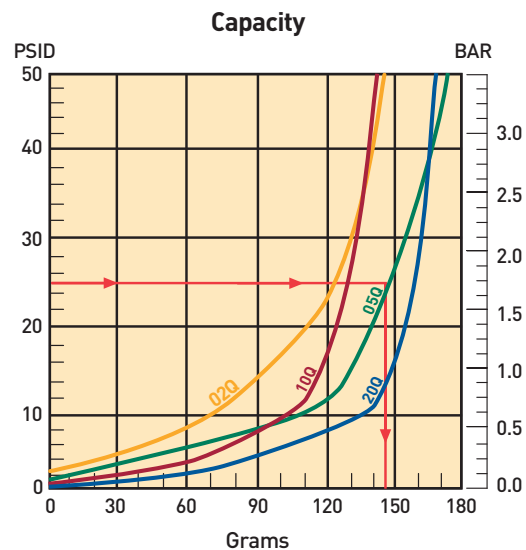

To determine element life:

1. Choose the desired change out pressure on the vertical axis.
2. Draw a horizontal line until it intersects the media grade desired.
3. Draw a perpendicular vertical line downwards until it intersects the horizontal axis and record value. This will tell you approximately how many grams of dirt the element will hold before changeout is needed.

# Appendix

## Definitions

<b>Aerosol</b>	Submicronic particles suspended in air, gas or vapor. A fog, fume, or smoke.
<b>Bulk Density</b>	Ratio of total mass or weight of the material divided by the volume of the material (includes void volume in the case of solids).
<b>Coalesce</b>	To unite small droplets of one liquid preparatory to its being separated from another liquid. Filter/coalescer elements coalesce small water droplets present in water contaminated fuel and certain oils into larger drops which are then separated by gravity.
<b>Continuous Phase</b>	The basic product flowing through a filter or filter/separator which continues on through a system after being subjected to solids and/or water removal.
<b>Delta P</b>	See “Pressure Drop” below.
<b>Discontinuous Phase</b>	The phase dispersed in the continuous phase; water is a discontinuous phase to be separated from a hydrocarbon liquid or from air or gas.
<b>Drop</b>	The quantity of liquid which makes up one spherical mass; a liquid globule.
<b>Droplet</b>	A small drop which may coalesce to form larger drops.
<b>Effluent</b>	Stream of fluid at the outlet of a filter or filter/separator. Opposite of influent.
<b>Emulsion</b>	A dispersion of fine droplets in the continuous phase.
<b>Fiber Migration</b>	Carry-over of fibers from filter or separator media material into the effluent. Fiber migration is a qualitative part of total media migration.
<b>Filtrate</b>	The fluid which has passed through filtering media. Also referred to as effluent from filters.
<b>Gravity Separation</b>	Separation of immiscible phases resulting from a difference in specific gravity.
<b>Hydrophilic</b>	Water accepting or water wettable. Opposite of hydrophobic.
<b>Hydrophobic</b>	Water repelling. Lacking affinity for water. Opposite of hydrophilic.
<b>Immiscible</b>	Liquids which are mutually insoluble; opposite of miscible.

# Appendix

## Definitions

<b>Influent</b>	Stream of fluid at the inlet of a filter or filter/separator. Opposite of effluent.
<b>Media Migration</b>	Carry-over of fibers and particles from filter or separator media material into the effluent. Includes fiber migration, expressed as milligrams per liter.
<b>Miscible</b>	Liquids which are mutually soluble. Opposite of immiscible.
<b>Pressure Drop (Delta P: <math>\Delta P</math>)</b>	The difference in pressure between two points, generally at the inlet and outlet of a filter or a filter/separator. Measured in pounds per square inch, inches of mercury, kilograms per square centimeter, kilopascals (kPa) or bars (1 bar = 14.5 psi). (Also commonly referred to as Delta P or differential pressure.)
<b>Specific Gravity</b>	The ratio of weight of a fluid to the weight of an equal volume of standard substance; i.e. water for solids and liquids, and air or hydrogen for gases.
<b>Static Generation</b>	Unbalanced or net electrical charge produced in a flowing hydrocarbon liquid.
<b>Surfactants</b>	Surface-active agents, which are also called detergents, emulsifiers, or wetting agents. Polar compounds. (Most surfactants in jet fuel can be removed by clay treatment.)
<b>Three-Stage</b>	A filter/separator vessel containing coalescers, separators and 3rd stage monitor elements.
<b>Two-Stage</b>	A filter/separator containing two kinds or types of elements (coalescers and separators).
<b>Velocity</b>	The time rate of motion or speed in a given direction.
<b>Viscosity</b>	A molecular property of fluids: the friction of molecular motion. A more viscous fluid has a higher pressure drop at a given rate of flow, as compared to a less viscous fluid.

# Appendix

## Micrometer Conversions

US & ASTM Std Sieve Number	Actual Opening (in)	( $\mu\text{m}$ )
10	0.0787	2000
12	0.0661	1680
14	0.0555	1410
16	0.0469	1190
18	0.0394	1000
20	0.0331	840
25	0.0280	710
30	0.0232	590
35	0.0197	500
40	0.0165	420
45	0.0138	350
50	0.0117	297
60	0.0098	250
70	0.0083	210
80	0.0070	177
100	0.0059	149
120	0.0049	125
140	0.0041	105
170	0.0035	88
200	0.0029	74
230	0.0024	62
270	0.0021	53
325	0.0017	44
400	0.00142	36
550	0.00099	25
625	0.00079	20
1,250	0.000394	10
1,750	0.000315	8
2,500	0.00097	5
5,000	0.000099	2.5
12,000	0.0000394	1

## Relative Size of Particles

Magnification 500x

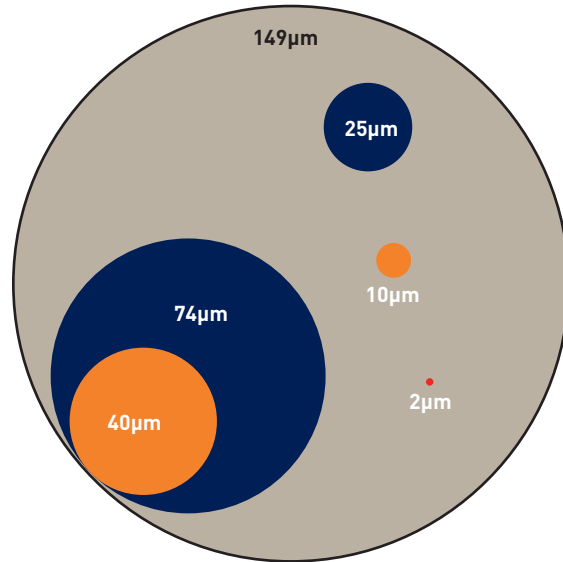

## Micrometer Comparisons

Substance	( $\mu\text{m}$ )
Table Salt	100
Human Hair (average diameter)	50-70
White Blood Cell	25
Talcum Powder	10
Cocoa	8-10
Red Blood Cell	8
Bacteria (cocci)	2

Note: Lower limit of visibility (naked eye)—40 $\mu\text{m}$

### Formulas

$$\text{Velocity (ft per sec)} = \frac{0.4085 \times \text{gpm}}{d^2 \text{ (ID in)}}$$

### Metric Conversion Formulas

mm	=	inches x 25.4
m	=	feet x 0.3048
cm <sup>3</sup>	=	cu in x 16.39
m <sup>3</sup>	=	cu ft x 0.028
kg	=	pounds x 0.454
kPa	=	psi x 6.895
lpm	=	gpm x 3.785
°C	=	5/9 (°F-32)

### Conversion Rates

1 cu ft	=	7.48 gal
1 gal	=	231 cu in
2 cu ft water	=	62.42 lb
1 gal water	=	8.34 lb
1 US gal	=	0.833 Imp gal
1 lb/in <sup>2</sup>	=	2.31 ft of water = 2.036 in Hg
°F	=	9/5°C+32

### Linear Equivalents

1 in	=	25.4 mm	=	25,400 $\mu\text{m}$
1 mm	=	0.0394 in	=	1,000 $\mu\text{m}$
1 $\mu\text{m}$	=	1/25,400 in	=	0.001 mm
1 $\mu\text{m}$	=	3.94 x 10 <sup>-5</sup> in	=	0.000039 in

# Appendix

## Measurement Conversion Tables

To Convert	Multiply by	To Obtain
<b>A</b>		
atmospheres	33.9	ft of water (at 4×C)
atmospheres	29.92	in mercury (at 0×C)
<b>B</b>		
barrels (US liquid)	31.5	gallons
barrels (oil)	42	gallons (oil)
bars	0.9869	atmospheres
bars	14.5	pounds/sq in
<b>C</b>		
centimeters	0.03281	feet
centimeters	0.3937	inches
centimeters	0.00001	kilometers
centimeters	0.01	meters
centimeters	0.01094	yards
centimeters	10,000	microns
cubic centimeters	0.00003531	cubic feet
cubic centimeters	0.06102	cubic inches
cubic centimeters	0.000001	cubic meters
cubic centimeters	0.001	liters
cubic centimeters	0.002113	pints (US liquid)
cubic centimeters	0.001057	quarts (US liquid)
cubic feet	28,320	cubic centimeters
cubic feet	1,728	cubic inches
cubic feet	0.02832	cubic meters
cubic feet	0.03704	cubic yards
cubic feet	7.48052	gallons (US liquid)
cubic feet	28.32	liters
cubic feet	59.84	pints (US liquid)
cubic feet	29.92	quarts (US liquid)
cubic feet/min	62.43	pounds water/min
cubic feet/min	1.698	cubic meters/hr
cubic feet/sec	448.831	gallons/min
cubic inches	16.39	cubic centimeters
cubic inches	0.0005787	cubic feet
cubic inches	0.00001639	cubic meters
cubic inches	0.00002143	cubic yards
cubic inches	0.004329	gallons
cubic inches	0.01639	liters
cubic meters	35.31	cubic feet
cubic meters	61,023	cubic inches
cubic meters	264.2	gallons (US liquid)
cubic meters	1000	liters
cubic meters/hour	4.4	gallons (US)/min
cubic meters/hour	0.588	cubic feet/min

To Convert	Multiply by	To Obtain
<b>F</b>		
feet	30.48	centimeters
feet	0.0003048	kilometers
feet	0.3048	meters
feet	304.8	millimeters
feet of water	0.0295	atmospheres
feet of water	0.8826	inches of mercury
feet of water	62.43	pounds/sq ft
feet of water	0.4335	pounds/sq in
feet/minute	0.01667	feet/second
<b>G</b>		
gallons	3,785	cubic centimeters
gallons	0.1337	cubic feet
gallons	231	cubic inches
gallons	3.785	liters
gallons (liq br imp)	1.20095	gallons (US liquid)
gallons (US)	0.83267	gallons (Imp)
gallons of water	8.337	pounds of water
gallons/min	0.002228	cubic feet/sec
gallons/min	0.06308	liters/sec
gallons/min	8.0208	cubic feet/hr
grams	0.001	kilograms
grams	0.002205	pounds
grams/cm	0.0056	pounds/in
grams/sq in	45.71	ounces/sq yd
<b>I</b>		
inches	2.540	centimeters
inches	0.02540	meters
inches	25.4	millimeters
inches of mercury	0.03342	atmospheres
inches of mercury	1.133	feet of water
<b>K</b>		
kilograms	2.2046	pounds
kilograms	0.009842	tons (long)
kilograms	0.001102	tons (short)
kilograms/sq cm	2,048	pounds/sq ft
kilograms/sq cm	14.22	pounds/sq in
kilograms/sq meter	0.00009678	atmospheres
kilograms/sq meter	0.00009807	bars
kilograms/sq meter	0.003281	feet of water
kilograms/sq meter	0.002896	inches of mercury
kilograms/sq meter	0.2048	pounds/sq ft
kilograms/sq meter	0.001422	pounds/sq in

# Appendix

## Measurement Conversion Tables

To Convert	Multiply by	To Obtain
<b>L</b>		
liters	0.2642	gallons (US liquid)
liters	2.113	pints (US liquid)
liters	1.057	quarts (US liquid)
liters/min	0.0005886	cubic ft/sec
liters/min	0.004403	gallons/sec
liters/hour	0.004403	gallons (US)/min

<b>M</b>		
meters	3.281	feet
meters	39.37	inches
meters	0.001	kilometers
meters/min	3.281	feet/min
meters/min	0.05468	feet/sec
microns	0.000001	meters
mils	0.00254	centimeters
mils	0.0000833333	feet
mils	0.001	inches
mils	0.0000000254	kilometers

<b>O</b>		
ounces	28.349	grams
ounces	0.0625	pounds
ounces (fluid)	1.805	cubic inches
ounces (fluid)	0.02957	liters
ounces/sq in	0.0625	pounds/sq in
ounces/sq yard	20.83	pounds/3000 sq ft

<b>P</b>		
pints (liquid)	0.125	gallons
pints (liquid)	0.4732	liters
pints (liquid)	0.5	quarts (liquid)
pounds	453.59	grams
pounds	16	ounces
pounds/sq ft	0.0004725	atmospheres
pounds/sq ft	0.01602	feet of water
pounds/sq ft	0.01414	inches of mercury
pounds/sq in	0.06804	atmospheres
pounds/sq in	2.307	feet of water
pounds/sq in	2.036	inches of mercury
pounds/sq in	0.0145	kilo pascals (kPa)
pounds/sq in	27.684	inches water column
pounds/3000 sq in	0.048	ounces/sq yard

To Convert	Multiply by	To Obtain
<b>Q</b>		
quarts (liquid)	0.03342	cubic feet
quarts (liquid)	57.75	cubic inches
quarts (liquid)	0.0009464	cubic meters
quarts (liquid)	0.25	gallons
quarts (liquid)	0.9463	liters

<b>S</b>		
square centimeters	0.001076	square feet
square centimeters	0.1550	square inches
square centimeters	0.0001	square meters
square feet	144	square inches
square feet	0.0929	square meters
square inches	0.006944	square feet
square inches	0.0007716	square yards
square meters	10.76	square feet
square meters	155	square inches
square meters	1.196	square yards
square yards	9	square feet
square yards	1,296	square inches
square yards	0.8361	square meters

# Appendix

## ISO 4406 Codes

Specifying proper filtration has become more difficult since the days of “nominal” rated filters. Rather than guessing on nominal, absolute, or Beta ratings, it makes more sense instead to specify how clean you want the fuel to be and let the filter manufacturer provide the proper element to attain that cleanliness. The International Standards Organization (ISO) has developed a method of describing fluid cleanliness called ISO 4406 Solid Contamination Level Code, commonly referred to as the ISO Cleanliness Code. This method is based on particle counting and is expressed by a set of 3 code numbers, each ranging from 1 to 28. Each code number represents particle counts from .01 particles per milliliter of fluid to 2,500,000

particles per milliliter. The three code numbers are separated by a slash and are written as shown in the following example:

14/11/8. The first code number represents the particle count range of all particles greater than 4 microns in size, the second number represents the count range of particles greater than 6 microns, and the third number represents that of all particles greater than 14 microns. The table below shows the ISO 4406 code levels.

Prior to 1999, ISO Codes were expressed as only two numbers, such as “14/11”, which represented the number of particles greater than 5 microns and greater than 15 microns. Due to differences in test

methods and test contaminants, the 6 and 14 micron sizes of the new revision correspond to the 5 and 15 micron sizes of the original standard.

Equipment manufacturers can provide the level of fluid cleanliness required for proper operation of their equipment. More and more, diesel engine manufacturers are beginning to specify the level of fuel cleanliness required for modern diesel engines.

Once the application conditions such as fuel type, flow rate, operating temperature, reservoir size, etc. are provided, the proper filter housing and element can be selected to meet a desired fluid cleanliness requirement.

ISO 4406:1999 Code Chart		
Range Code	Particles per milliliter	
	More Than	Up To/Including
24	80,000	160,000
23	40,000	80,000
22	20,000	40,000
21	10,000	20,000
20	5,000	10,000
19	2,500	5,000
18	1,300	2,500
17	640	1,300
16	320	640
15	160	320
14	80	160
13	40	80
12	20	40
11	10	20
10	5	10
9	2.5	5
8	1.3	2.5
7	0.64	1.3
6	0.32	0.64

Particle Size $\mu\text{m}$	Particle per mL	ISO Code 4406 Range	ISO Code
4	151700	80000 - 160000	24
6	57233	40000 - 80000	23
14	27562	20000 - 40000	22
30	2965	2500 - 5000	19

Particle Size $\mu\text{m}$	Particle per mL	ISO Code 4406 Range	ISO Code
4	520	320 - 640	16
6	173	160 - 320	15
14	37	20 - 40	12
30	11	10 - 20	11

# Appendix

## Maintenance and Safety Recommendations

### Maintenance

#### Everytime you receive fuel:

Test a sample using Parker Condition Monitoring products.

#### Every day:

- **Drain the sump of each filter vessel and storage tank. Inspect samples for contamination particles and discolored water. Be sure all accumulated water is drained off.**
- **Check and record the pressure differential across each filter housing under normal flow conditions.**

#### Once a year:

- **Inspect your storage tanks and clean them if needed.**
- **Change your coalescer elements and any pleated cellulose separator elements. Your Parker representative can help you get the right element sets.**
- **Clean, inspect, and test any Teflon™ coated screen separators.**

### Safety

A sudden decrease in pressure differential across a filter housing may mean trouble. The vessel should be opened immediately and inspected for ruptured elements, seals or mounting hardware. It's also possible to get a decrease in pressure differential without any of these failures. It can happen if elements that have been separating water from the fuel now are exposed to dry fuel. The water is slowly pushed out of the coalescer, resulting in decreased differential pressure.

Fires start from sparks caused by electrostatic buildup. Here's how you can prevent them. Follow these simple steps and you won't start a fire when you fill a filter vessel:

1. **Close the outlet valve and the drain valves.**
2. **Crack open the inlet valve slightly so that the vessel will fill slowly to prevent charge buildup.**
3. **Start the pump.**
4. **If you have a manual air eliminator, open it completely.**
5. **Allow about 10 minutes to fill the vessel. If it fills faster than that, you're taking a chance.**
6. **Remember to close the air eliminator when the vessel is full.**
7. **If the vessel has an automatic air eliminator with a check valve, you had to remove the check valve before you could drain. Remember to put it back.**

Some simple ways to stay out of trouble when you change elements..

- **Drain the filter housing completely. Otherwise, the dirt can fall out of the element and contaminate the fuel. If you open the air eliminator, the vessel drains faster. Remove the used elements.**
- **Don't touch the new coalescer and separator elements. Leave the polybags on the elements as you install them. And before you close the vessel, take the bags off slowly to avoid building up an electrostatic charge. If you have to handle the elements, wear clean cotton or rubber gloves. Don't touch the separator's Teflon™ screen. Handle it by the endcaps.**
- **Always use a torque wrench for installing elements. Read the manufacturer's specified torque value in the installation instructions.**
- **When you clean the inside of a filter vessel, use the product being filtered or diluted bleach. Do not use soap or another type of fuel.**
- **Close all the drain valves before you refill. Obvious, but easy to forget!**

# Appendix

## Recommended Manual Drain Hookup

### Particulate/Separator Vessels

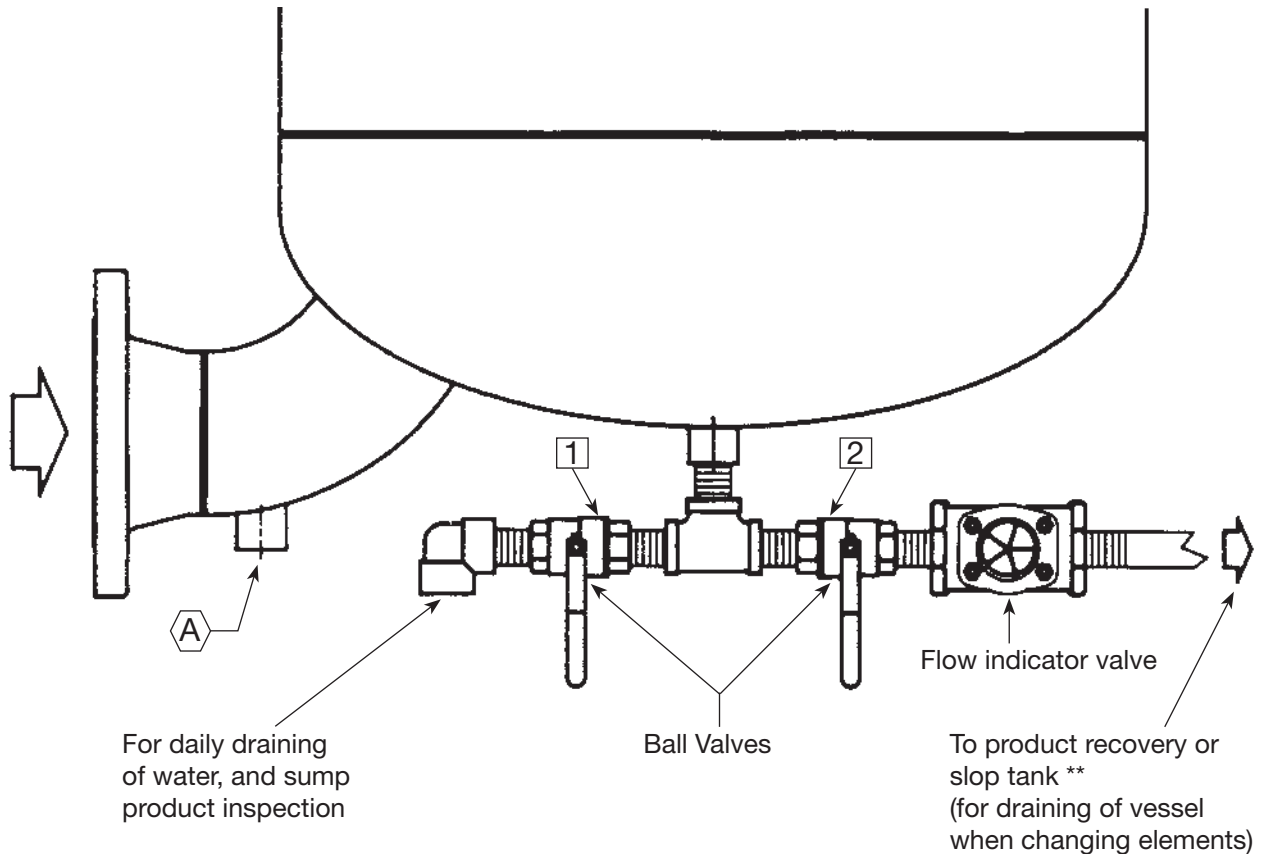

#### **\*\*When draining vessel to change elements:**

1. Drain vessel completely through ball valve #2 above.
2. Drain a few gallons out of manual drain valve "A" (or plug) located at the bottom of the inlet elbow. This insures no fuel remains trapped inside coalescers. (Otherwise unfiltered fuel from inside the coalescers could make clean-up of the sump more tedious.)

#### **NOTE:**

A flow indicator valve (not provided by Parker) is recommended so that operator will remember to close valve #2 when filling the vessel. It also shows operator when the vessel is completely drained.

# Appendix

## Assembly Torque Recommendations

### COALESCER ELEMENTS

DI-6xxTB  
Threaded Base Element

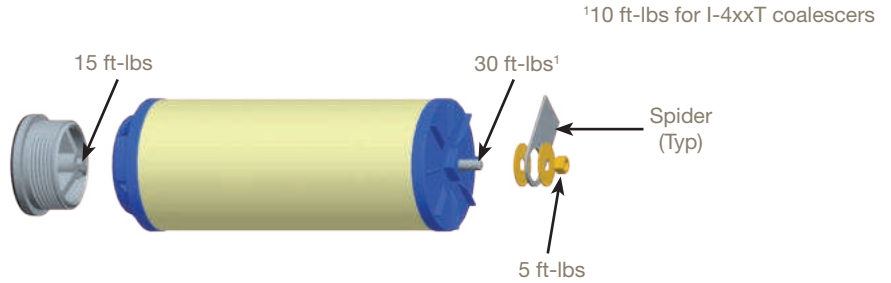

DI-6xx  
Open Ended Element

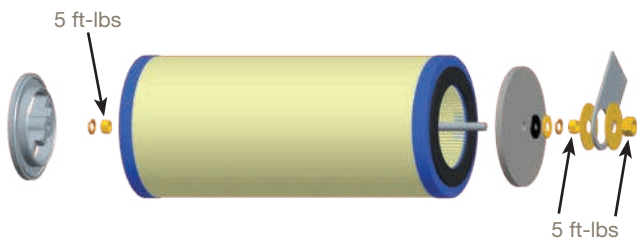

### SEPARATOR ELEMENTS<sup>2</sup>

DSO-6xxC/PL

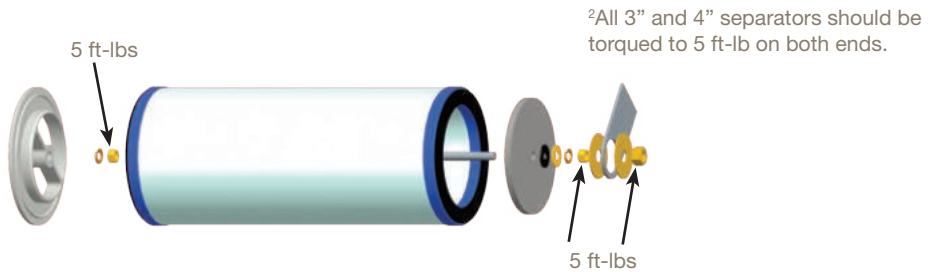

DSO-6xxTB  
Threaded Base Element



### TORQUE CONVERSION TABLE

ft-lbs	inch-lbs	kg-m	N-m
5	60	0.69	6.78
10	120	1.38	13.56
15	180	2.07	20.34
20	240	2.77	27.12
30	360	4.15	40.67

# Appendix

## Assembly Torque Recommendations

### PARTICULATE ELEMENTS

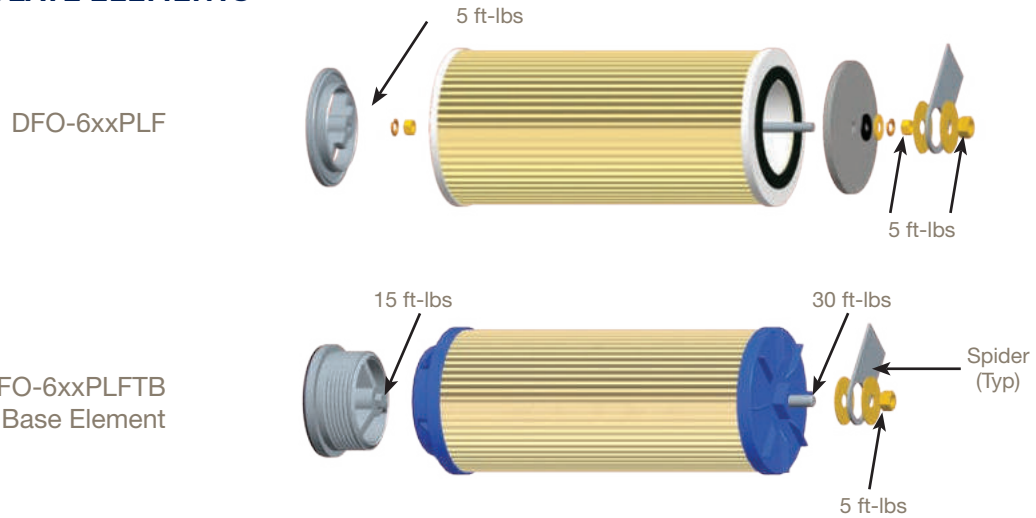

### Aquacon® ELEMENTS

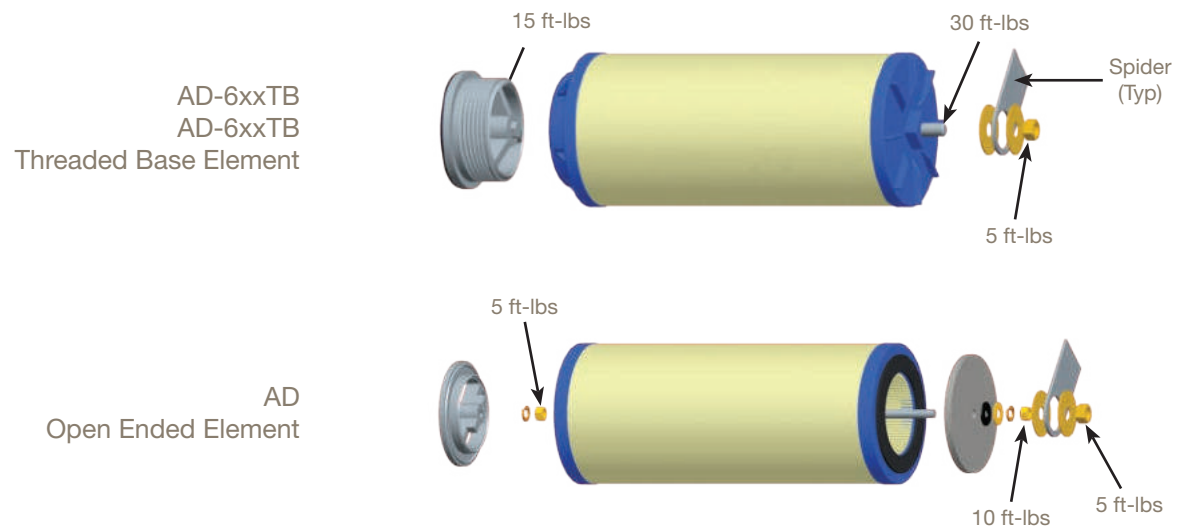

### TORQUE CONVERSION TABLE

ft-lbs	inch-lbs	kg-m	N-m
5	60	0.69	6.78
10	120	1.38	13.56
15	180	2.07	20.34
20	240	2.77	27.12
30	360	4.15	40.67





# Hydraulic & Fuel Filtration Division

Your prescription for total system health.

Dedicated to the long term health and reliability of mission critical assets, Parker Hydraulic & Fuel Filtration Division offers you innovative products that cover your diagnostic, therapeutic and preventive needs.



## Total System Health Management



**Diagnostic**  
Monitors  
Detects  
Alerts



**Therapeutic**  
Supports  
Improves  
Fortifies



**Preventive**  
Long Term Defense  
Long Term Value  
Reduced Cost of Ownership



**Your Trusted Partner in Total System Health Management**





# Non-Standard Configuration Form

**Date:** \_\_\_\_\_  
**To:** 419 644 6205 Fax / hfdinsidesales@parker.com  
 Parker Hannifin Corporation  
 Hydraulic & Fuel Filtration Division  
**ATTN:** Inside Sales

**From**  
**Name:** \_\_\_\_\_  
**Company:** \_\_\_\_\_  
**Fax No.:** \_\_\_\_\_  
**Phone No.:** \_\_\_\_\_  
**Email :** \_\_\_\_\_

**Please send all written customers specifications.**  
**Fill out and send this sheet whenever written specifications are lacking or incomplete.**

**Customer:** \_\_\_\_\_ **Destination:** \_\_\_\_\_

**Equipment Required:**

- Filter/Separator       Particulate filter       **Aquacon®** Element Housing

**Micron Rating for Microfilter or Aquacon® Element:** \_\_\_\_\_

**Product (Fuel):** \_\_\_\_\_ **Biodiesel Type:** \_\_\_\_\_ %

**Qty. Required:** \_\_\_\_\_ **Flow Rate:** \_\_\_\_\_ US gpm      **Design Pressure:**  150 psi       **Other:** \_\_\_\_\_

**Vertical**       **Horizontal**       **Fixed**       **Mobile**

Corrosion Allowance      Specify if applicable \_\_\_\_\_

Temperature:  20 -200F Standard       Specify if different \_\_\_\_\_

Primer Exterior       Specify if different \_\_\_\_\_

Epoxy Interior Standard

Oil coat interior. If not epoxy, specify other: \_\_\_\_\_

**ACCESSORIES**

**Standard**

- Auto. Air Eliminator**       St. Steel
- Auto. Air Check Valve**       St. Steel
- Pressure Relief Valve**       Steel
- Pressure Gauge**       0-30 Alum
- Float Control**       Alum. (Separator Only)
- Slug Valve**       Ductile Iron (Separator Only)
- Manual Drain**       Steel
- Water Probe**       Single Stage
- Sample Probes**       GTP Kit #5
- Heater**       240V
- Sight Glass**       St. Steel

**ASME Code Cert. & Stamp**

**Export Packing**

**Budget Quote**       **Firm Requirement**       **Date Quote is Required:** \_\_\_\_\_

**Probability of Converting:** \_\_\_\_\_ %      **Est. Win Date:** \_\_\_\_\_

**Other Requirements:** \_\_\_\_\_

---



---



---



# Offer of Sale

The goods, services or work (referred to as the "Products") offered by Parker-Hannifin Corporation, its subsidiaries, groups, divisions, and authorized distributors ("Seller") are offered for sale at prices indicated in the offer, or as may be established by Seller. The offer to sell the Products and acceptance of Seller's offer by any customer ("Buyer") is contingent upon, and will be governed by all of the terms and conditions contained in this Offer of Sale. Buyer's order for any Products specified in Buyer's purchase document or Seller's offer, proposal or quote ("Quote") attached to the purchase order, when communicated to Seller verbally, or in writing, shall constitute acceptance of this offer.

1. **Terms and Conditions.** Seller's willingness to offer Products for sale or accept an order for Products is subject to the terms and conditions contained in this Offer of Sale or any newer version of the same, published by Seller electronically at [www.parker.com/saleterms/](http://www.parker.com/saleterms/). Seller objects to any contrary or additional terms or conditions of Buyer's order or any other document or other communication issued by Buyer.

2. **Price; Payment.** Prices stated on Seller's Quote are valid for thirty (30) days, except as explicitly otherwise stated therein, and do not include any sales, use, or other taxes or duties unless specifically stated. Seller reserves the right to modify prices to adjust for any raw material price fluctuations. Unless otherwise specified by Seller, all prices are F.C.A. Seller's facility (INCOTERMS 2010). Payment is subject to credit approval and payment for all purchases is due thirty (30) days from the date of invoice (or such date as may be specified by Seller's Credit Department). Unpaid invoices beyond the specified payment date incur interest at the rate of 1.5% per month or the maximum allowable rate under applicable law.

3. **Shipment; Delivery; Title and Risk of Loss.** All delivery dates are approximate. Seller is not responsible for damages resulting from any delay. Regardless of the manner of shipment, delivery occurs and title and risk of loss or damage pass to Buyer, upon placement of the Products with the shipment carrier at Seller's facility. Unless otherwise stated, Seller may exercise its judgment in choosing the carrier and means of delivery. No deferral of shipment at Buyer's request beyond the respective dates indicated will be made except on terms that will indemnify, defend and hold Seller harmless against all loss and additional expense. Buyer shall be responsible for any additional shipping charges incurred by Seller due to Buyer's acts or omissions.

4. **Warranty.** Seller warrants that the Products sold hereunder shall be free from defects in material or workmanship for a period of twelve (12) months from the date of delivery or 2,000 hours of normal use, whichever occurs first. All prices are based upon the exclusive limited warranty stated above, and upon the following disclaimer: **DISCLAIMER OF WARRANTY: THIS WARRANTY IS THE SOLE AND ENTIRE WARRANTY PERTAINING TO PRODUCTS PROVIDED. SELLER DISCLAIMS ALL OTHER WARRANTIES, EXPRESS AND IMPLIED, INCLUDING DESIGN, MERCHANTABILITY AND FITNESS FOR A PARTICULAR PURPOSE.**

5. **Claims; Commencement of Actions.** Buyer shall promptly inspect all Products upon receipt. No claims for shortages will be allowed unless reported to the Seller within ten (10) days of delivery. No other claims against Seller will be allowed unless asserted in writing within thirty (30) days after delivery. Buyer shall notify Seller of any alleged breach of warranty within thirty (30) days after the date the defect is or should have been discovered by Buyer. Any claim or action against Seller based upon breach of contract or any other theory, including tort, negligence, or otherwise must be commenced within twelve (12) months from the date of the alleged breach or other alleged event, without regard to the date of discovery.

6. **LIMITATION OF LIABILITY. IN THE EVENT OF A BREACH OF WARRANTY, SELLER WILL, AT ITS OPTION, REPAIR OR REPLACE A DEFECTIVE PRODUCT, OR REFUND THE PURCHASE PRICE WITHIN A REASONABLE PERIOD OF TIME. IN NO EVENT IS SELLER LIABLE FOR ANY SPECIAL, INDIRECT, INCIDENTAL OR CONSEQUENTIAL DAMAGES ARISING OUT OF, OR AS THE RESULT OF, THE SALE, DELIVERY, NON-DELIVERY, SERVICING, USE OR LOSS OF USE OF THE PRODUCTS OR ANY PART THEREOF, OR FOR ANY CHARGES OR EXPENSES OF ANY NATURE INCURRED WITHOUT SELLER'S WRITTEN CONSENT, WHETHER BASED IN CONTRACT, TORT OR OTHER LEGAL THEORY. IN NO EVENT SHALL SELLER'S LIABILITY UNDER ANY CLAIM MADE BY BUYER EXCEED THE PURCHASE PRICE OF THE PRODUCTS.**

7. **User Responsibility.** The user, through its own analysis and testing, is solely responsible for making the final selection of the system and Product and assuring that all performance, endurance, maintenance, safety and warning requirements of the application are met. The user must analyze all aspects of the application and follow applicable industry standards and Product information. If Seller provides Product or system options based upon data or specifications provided by the user, the user is responsible for determining that such data and specifications are suitable and sufficient for all applications and reasonably foreseeable uses of the Products or systems.

8. **Loss to Buyer's Property.** Any designs, tools, patterns, materials, drawings, confidential information or equipment furnished by Buyer or any other items which become Buyer's property, will be considered obsolete and may be destroyed by Seller after two (2) consecutive years have elapsed without Buyer ordering the items manufactured using such property. Seller shall not be responsible for any loss or damage to such property while it is in Seller's possession or control.

9. **Special Tooling.** A tooling charge may be imposed for any special tooling, including without limitation, dies, fixtures, molds and patterns, acquired to manufacture Products. Such special tooling shall be and remain Seller's property notwithstanding payment of any charges by Buyer. In no event will Buyer acquire any interest in apparatus belonging to Seller which is utilized in the manufacture of the Products, even if such apparatus has been specially converted or adapted for such manufacture and notwithstanding any charges paid by Buyer. Unless otherwise agreed, Seller has the right to alter, discard or otherwise dispose of any special tooling or other property in its sole discretion at any time.

10. **Buyer's Obligation; Rights of Seller.** To secure payment of all sums due or otherwise, Seller retains a security interest in all Products delivered to Buyer and this agreement is deemed to be a Security Agreement under the Uniform Commercial Code. Buyer authorizes Seller as its attorney to execute and file on Buyer's behalf all documents Seller deems necessary to perfect its security interest.

11. **Improper Use and Indemnity.** Buyer shall indemnify, defend, and hold Seller harmless from any losses, claims, liabilities, damages, lawsuits, judgments and costs (including attorney fees and defense costs), whether for personal injury, property damage, patent,

trademark or copyright infringement or any other claim, brought by or incurred by Buyer, Buyer's employees, or any other person, arising out of: (a) improper selection, application, design, specification or other misuse of Products purchased by Buyer from Seller; (b) any act or omission, negligent or otherwise, of Buyer; (c) Seller's use of patterns, plans, drawings, or specifications furnished by Buyer to manufacture Products; or (d) Buyer's failure to comply with these terms and conditions. Seller shall not indemnify Buyer under any circumstance except as otherwise provided.

12. **Cancellations and Changes.** Buyer may not cancel or modify or cancel any order for any reason, except with Seller's written consent and upon terms that will indemnify, defend and hold Seller harmless against all direct, incidental and consequential loss or damage. Seller may change Product features, specifications, designs and availability.

13. **Limitation on Assignment.** Buyer may not assign its rights or obligations under this agreement without the prior written consent of Seller.

14. **Force Majeure.** Seller does not assume the risk and is not liable for delay or failure to perform any of Seller's obligations by reason of events or circumstances beyond its reasonable control (hereinafter "Events of Force Majeure"). Events of Force Majeure shall include without limitation: accidents, strikes or labor disputes, acts of any government or government agency, acts of nature, delays or failures in delivery from carriers or suppliers, shortages of materials, or any other cause beyond Seller's reasonable control.

15. **Waiver and Severability.** Failure to enforce any provision of this agreement will not invalidate that provision; nor will any such failure prejudice Seller's right to enforce that provision in the future. Invalidation of any provision of this agreement by legislation or other rule of law shall not invalidate any other provision herein. The remaining provisions of this agreement will remain in full force and effect.

16. **Termination.** Seller may terminate this agreement for any reason and at any time by giving Buyer thirty (30) days prior written notice. Seller may immediately terminate this agreement, in writing, if Buyer: (a) breaches any provision of this agreement (b) appoints a trustee, receiver or custodian for all or any part of Buyer's property (c) files a petition for relief in bankruptcy on its own behalf, or one if filed by a third party (d) makes an assignment for the benefit of creditors; or (e) dissolves its business or liquidates all or a majority of its assets.

17. **Governing Law.** This agreement and the sale and delivery of all Products are deemed to have taken place in, and shall be governed and construed in accordance with, the laws of the State of Ohio, as applicable to contracts executed and wholly performed therein and without regard to conflicts of laws principles. Buyer irrevocably agrees and consents to the exclusive jurisdiction and venue of the courts of Cuyahoga County, Ohio with respect to any dispute, controversy or claim arising out of or relating to this agreement.

18. **Indemnity for Infringement of Intellectual Property Rights.** Seller is not liable for infringement of any patents, trademarks, copyrights, trade dress, trade secrets or similar rights except as provided in this Section. Seller will defend and indemnify Buyer against allegations of infringement of U.S. patents, U.S. trademarks, copyrights, trade dress and trade secrets ("Intellectual Property Rights"). Seller will defend at its expense and will pay the cost of any settlement or damages awarded in an action brought against Buyer based on an allegation that a Product sold pursuant to this agreement infringes the Intellectual Property Rights of a third party. Seller's obligation to defend and indemnify Buyer is contingent on Buyer notifying Seller within ten (10) days after Buyer becomes aware of such allegations of infringement, and Seller having sole control over the defense of any allegations or actions including all negotiations for settlement or compromise. If a Product is subject to a claim that it infringes the Intellectual Property Rights of a third party, Seller may, at its sole expense and option, procure for Buyer the right to continue using the Product, replace or modify the Product so as to make it noninfringing, or offer to accept return of the Product and refund the purchase price less a reasonable allowance for depreciation. Notwithstanding the foregoing, Seller is not liable for claims of infringement based on information provided by Buyer, or directed to Products delivered hereunder for which the designs are specified in whole or part by Buyer, or infringements resulting from the modification, combination or use in a system of any Product sold hereunder. The foregoing provisions of this Section constitute Seller's sole and exclusive liability and Buyer's sole and exclusive remedy for infringement of Intellectual Property Rights.

19. **Entire Agreement.** This agreement contains the entire agreement between the Buyer and Seller and constitutes the final, complete and exclusive expression of the terms of sale. All prior or contemporaneous written or oral agreements or negotiations with respect to the subject matter are herein merged. The terms contained herein may not be modified unless in writing and signed by an authorized representative of Seller.

20. **Compliance with Laws.** Buyer agrees to comply with all applicable laws, regulations, and industry and professional standards of care, including those of the United Kingdom, the United States of America, and the country or countries in which Buyer may operate, including without limitation the U. K. Bribery Act, the U.S. Foreign Corrupt Practices Act ("FCPA"), the U.S. Anti-Kickback Act ("Anti-Kickback Act") and the U.S. Food Drug and Cosmetic Act ("FDCA"), each as currently amended, and the rules and regulations promulgated by the U.S. Food and Drug Administration ("FDA"), and agrees to indemnify and hold harmless Seller from the consequences of any violation of such provisions by Buyer, its employees or agents. Buyer acknowledges that it is familiar with the provisions of the U. K. Bribery Act, the FCPA, the FDA, and the Anti-Kickback Act, and certifies that Buyer will adhere to the requirements thereof. In particular, Buyer represents and agrees that Buyer will not make any payment or give anything of value, directly or indirectly to any governmental official, any foreign political party or official thereof, any candidate for foreign political office, or any commercial entity or person, for the purpose of influencing such person to purchase Products or otherwise benefit the business of Seller.

5/2014

# Worldwide Filtration Manufacturing Locations

## North America

### Compressed Air Treatment

#### Gas Separation & Filtration Division

Airtek/Finite/domnick hunter/Zander  
Lancaster, NY  
716 686 6400  
[www.parker.com/faf](http://www.parker.com/faf)

Balston  
Haverhill, MA  
978 858 0505  
[www.parker.com/balston](http://www.parker.com/balston)

### Engine Filtration

#### Racor

Modesto, CA  
209 521 7860  
[www.parker.com/racor](http://www.parker.com/racor)

Holly Springs, MS  
662 252 2656  
[www.parker.com/racor](http://www.parker.com/racor)

### Hydraulic & Fuel Filtration

#### Hydraulic & Fuel Filtration

Metamora, OH  
419 644 4311  
[www.parker.com/hydraulicfilter](http://www.parker.com/hydraulicfilter)

Laval, QC Canada  
450 629 9594  
[www.parkerfarr.com](http://www.parkerfarr.com)

Velcon  
Colorado Springs, CO  
719 531 5855  
[www.velcon.com](http://www.velcon.com)

### Process Filtration

#### domnick hunter Process Filtration SciLog

Oxnard, CA  
805 604 3400  
[www.parker.com/processfiltration](http://www.parker.com/processfiltration)

### Water Purification

#### Village Marine, Sea Recovery, Horizon Reverse Osmosis

Carson, CA  
310 637 3400  
[www.parker.com/watermakers](http://www.parker.com/watermakers)

## Europe

### Compressed Air Treatment

#### domnick hunter Filtration & Separation

Gateshead, England  
+44 (0) 191 402 9000  
[www.parker.com/dhfn](http://www.parker.com/dhfn)

#### Parker Gas Separations

Etten-Leur, Netherlands  
+31 76 508 5300  
[www.parker.com/dhfn](http://www.parker.com/dhfn)

#### Hiross Zander

Essen, Germany  
+49 2054 9340  
[www.parker.com/hzfd](http://www.parker.com/hzfd)

Padova, Italy  
+39 049 9712 111  
[www.parker.com/hzfd](http://www.parker.com/hzfd)

### Engine Filtration & Water Purification

#### Racor

Dewsbury, England  
+44 (0) 1924 487 000  
[www.parker.com/rfde](http://www.parker.com/rfde)

#### Racor Research & Development

Stuttgart, Germany  
+49 (0)711 7071 290-10

### Hydraulic & Fuel Filtration

#### Hydraulic & Fuel Filtration

Arnhem, Holland  
+31 26 3760376  
[www.parker.com/hfde](http://www.parker.com/hfde)

Urdala, Finland  
+358 20 753 2500

#### Condition Monitoring Parker Kittiwake

West Sussex, England  
+44 (0) 1903 731 470  
[www.kittiwake.com](http://www.kittiwake.com)

### Process Filtration

#### domnick hunter Process Filtration Parker Twin Filter BV

Birtley, England  
+44 (0) 191 410 5121  
[www.parker.com/processfiltration](http://www.parker.com/processfiltration)

## Asia Pacific

### Australia

Castle Hill, Australia  
+61 2 9634 7777  
[www.parker.com/australia](http://www.parker.com/australia)

### China

Shanghai, China  
+86 21 5031 2525  
[www.parker.com/china](http://www.parker.com/china)

### India

Chennai, India  
+91 22 4391 0700  
[www.parker.com/india](http://www.parker.com/india)

### Parker Fowler

Bangalore, India  
+91 80 2783 6794  
[www.johnfowlerindia.com](http://www.johnfowlerindia.com)

### Japan

Tokyo, Japan  
+81 45 870 1522  
[www.parker.com/japan](http://www.parker.com/japan)

### Korea

Hwaseon-City  
+82 31 359 0852  
[www.parker.com/korea](http://www.parker.com/korea)

### Singapore

Jurong Town, Singapore  
+65 6887 6300  
[www.parker.com/singapore](http://www.parker.com/singapore)

### Thailand

Bangkok, Thailand  
+66 2186 7000  
[www.parker.com/thailand](http://www.parker.com/thailand)

## Latin America

### Parker Comercio Ltda. Filtration Division

Sao Paulo, Brazil  
+55 12 4009 3500  
[www.parker.com/br](http://www.parker.com/br)

### Pan American Division

Miami, FL  
305 470 8800  
[www.parker.com/panam](http://www.parker.com/panam)

## Africa

Aeroporto Kempton Park, South Africa  
+27 11 9610700  
[www.parker.com/africa](http://www.parker.com/africa)

